

JUMO GmbH & Co. KG
 Delivery address: Mackenrodtstraße 14
 36039 Fulda, Germany
 Postal address: 36035 Fulda, Germany
 Phone: +49 661 6003-0
 Fax: +49 661 6003-607
 Email: mail@jumo.net
 Internet: www.jumo.net

JUMO Instrument Co. Ltd.
 JUMO House
 Temple Bank, Riverway
 Harlow, Essex CM 20 2DY, UK
 Phone: +44 1279 63 55 33
 Fax: +44 1279 62 50 29
 Email: sales@jumo.co.uk
 Internet: www.jumo.co.uk

JUMO Process Control, Inc.
 6733 Myers Road
 East Syracuse, NY 13057, USA
 Phone: +1 315 437 5866
 Fax: +1 315 437 5860
 Email: info.us@jumo.net
 Internet: www.jumousa.com



JUMO compensation thermometers

Brief description

Temperature error can falsify the measurement signal during electrochemical measurements. Compensation thermometers are used to compensate measurement error caused by temperature. Compensation thermometers detect the temperature of the sample. The acquired signal is transferred to the downstream transmitter. In the transmitter, the measurement value is calculated back to the 25 °C reference temperature.



Type 201085/...

Technical data

Temperature range	-20 to +150 °C
Pressure range	With plug cap: unpressurized operation With Pg13.5 screw cap: 10 bar at 25 °C, 1 bar at 80 °C With Pg13.5 with M12 screw cap: 10 bar at 25 °C, 1 bar at 80 °C
Terminal head	Plug cap without thread (PPO) or Pg13.5 screw cap (PPO)
Process connection	No thread or Pg13.5 thread
Washer	PSU
Seal	FPM70
Shaft material	Glass (DIN 19263)
Active component	Pt100 DIN/IEC class B
Fitting length	120 mm (standard) Other fitting lengths on request

JUMO GmbH & Co. KG
 Delivery address: Mackenrodtstraße 14
 36039 Fulda, Germany
 Postal address: 36035 Fulda, Germany
 Phone: +49 661 6003-0
 Fax: +49 661 6003-607
 Email: mail@jumo.net
 Internet: www.jumo.net

JUMO Instrument Co. Ltd.
 JUMO House
 Temple Bank, Riverway
 Harlow, Essex CM 20 2DY, UK
 Phone: +44 1279 63 55 33
 Fax: +44 1279 62 50 29
 Email: sales@jumo.co.uk
 Internet: www.jumo.co.uk

JUMO Process Control, Inc.
 6733 Myers Road
 East Syracuse, NY 13057, USA
 Phone: +1 315 437 5866
 Fax: +1 315 437 5860
 Email: info.us@jumo.net
 Internet: www.jumousa.com



Dimensions

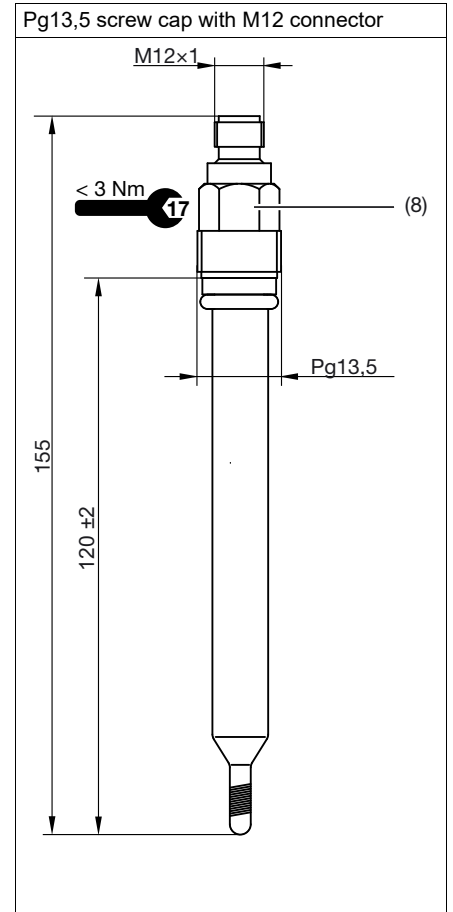
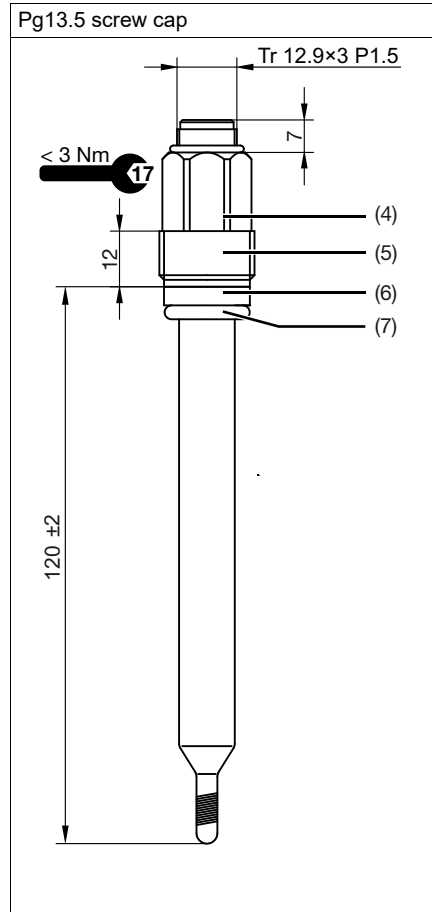
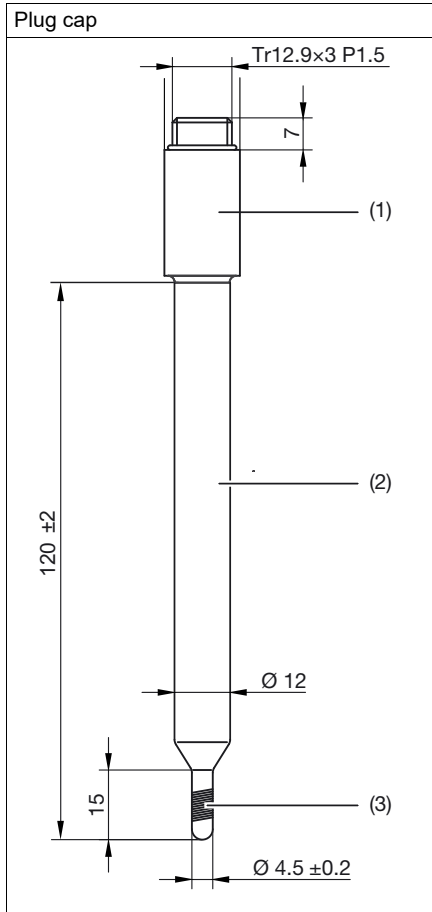

- | | | | |
|---|---------------------------|---|--|
| 1 | Plug cap | 2 | Shaft (glass DIN 19263) |
| 3 | Temperature sensor | 4 | Pg13.5 screw cap |
| 5 | Process connection Pg13.5 | 6 | Washer (PSU) |
| 7 | Seal (FMP70) | 8 | Pg13.5 screw cap with M12 connector, 4-pin, 713 series |

JUMO GmbH & Co. KG
 Delivery address: Mackenrodtstraße 14
 36039 Fulda, Germany
 Postal address: 36035 Fulda, Germany
 Phone: +49 661 6003-0
 Fax: +49 661 6003-607
 Email: mail@jumo.net
 Internet: www.jumo.net

JUMO Instrument Co. Ltd.
 JUMO House
 Temple Bank, Riverway
 Harlow, Essex CM 20 2DY, UK
 Phone: +44 1279 63 55 33
 Fax: +44 1279 62 50 29
 Email: sales@jumo.co.uk
 Internet: www.jumo.co.uk

JUMO Process Control, Inc.
 6733 Myers Road
 East Syracuse, NY 13057, USA
 Phone: +1 315 437 5866
 Fax: +1 315 437 5860
 Email: info.us@jumo.net
 Internet: www.jumousa.com



M12 connector pin assignment

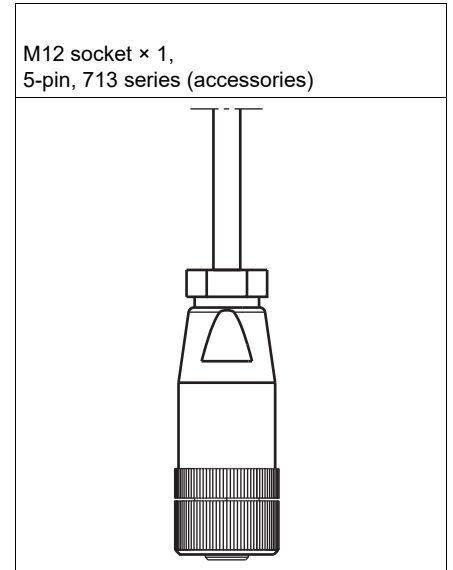
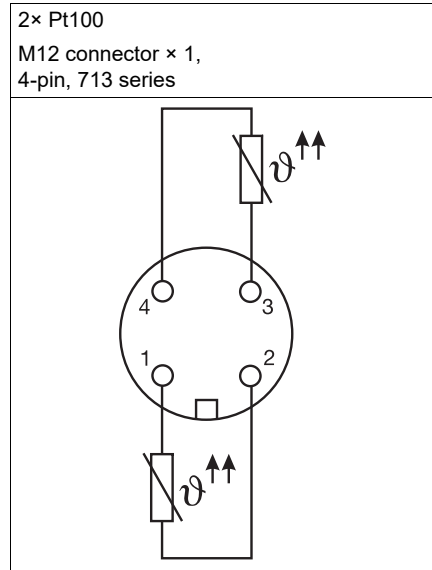
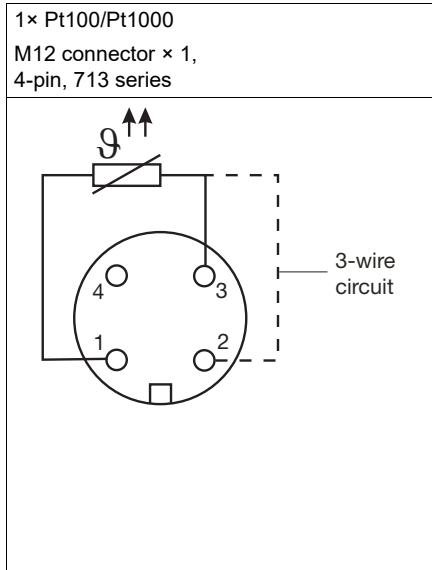

JUMO GmbH & Co. KG
 Delivery address: Mackenrodtstraße 14
 36039 Fulda, Germany
 Postal address: 36035 Fulda, Germany
 Phone: +49 661 6003-0
 Fax: +49 661 6003-607
 Email: mail@jumo.net
 Internet: www.jumo.net

JUMO Instrument Co. Ltd.
 JUMO House
 Temple Bank, Riverway
 Harlow, Essex CM 20 2DY, UK
 Phone: +44 1279 63 55 33
 Fax: +44 1279 62 50 29
 Email: sales@jumo.co.uk
 Internet: www.jumo.co.uk

JUMO Process Control, Inc.
 6733 Myers Road
 East Syracuse, NY 13057, USA
 Phone: +1 315 437 5866
 Fax: +1 315 437 5860
 Email: info.us@jumo.net
 Internet: www.jumousa.com



Order details

(1) Basic type	
201085	JUMO compensation thermometer
(2) Shaft material	
89	Glass
(3) Active component	
1001	1× Pt100 in three-wire circuit ^a
1003	1× Pt100 in two-wire circuit
1005	1× Pt1000 in two-wire circuit
1006	1× Pt1000 in three-wire circuit ^a
2003	2× Pt100 in two-wire circuit
(4) Connection	
21	Plug cap (S7)
22	Pg13.5 screw cap (S8)
70	Pg13.5 screw cap with M12 connector
(5) Insertion length	
120	120 mm (standard) ^b

^a Only possible in conjunction with connection 70.

^b Other fitting lengths on request.

Order code	<input type="text" value="(1)"/>	/	<input type="text" value="(2)"/>	-	<input type="text" value="(3)"/>	-	<input type="text" value="(4)"/>	-	<input type="text" value="(5)"/>
Order example	201085	/	89	-	1003	-	22	-	120

Note:

The order code is a type explanation – not a modular system for own sensor combinations.

If you wish your own combinations please ask the JUMO analytical measurement experts for prior approval.

Stock version

Item	Part no.
201085/89-1003-22-120	Compensation thermometer, 1× Pt100, Pg13.5 screw cap, 120 mm
	00300443

Manufacturing versions

Item	Part no.
201085/89-1003-70-120	Compensation thermometer, Pt100, Pg13.5 screw cap with M12 connector, 120 mm
	00492092
201085/89-1003-21-120	Compensation thermometer, Pt100, plug cap, 120 mm
	00300442

Accessories

Item	Part no.
5-pin M12 socket, in conjunction with connection 70 (Pg13.5 screw cap with M12 connector)	
	00458581