

JUMO GmbH & Co. KG
 Delivery address: Mackenrodtstraße 14
 36039 Fulda, Germany
 Postal address: 36035 Fulda, Germany
 Phone: +49 661 6003-0
 Fax: +49 661 6003-607
 Email: mail@jumo.net
 Internet: www.jumo.net

JUMO Instrument Co. Ltd.
 JUMO House
 Temple Bank, Riverway
 Harlow, Essex CM 20 2DY, UK
 Phone: +44 1279 63 55 33
 Fax: +44 1279 62 50 29
 Email: sales@jumo.co.uk
 Internet: www.jumo.co.uk

JUMO Process Control, Inc.
 6733 Myers Road
 East Syracuse, NY 13057, USA
 Phone: +1 315 437 5866
 Fax: +1 315 437 5860
 Email: info.us@jumo.net
 Internet: www.jumousa.com



JUMO AQUIS 500 pH

Transmitter/Controller for pH, ORP, NH₃ (ammonia) concentration and temperature

Brief description

The device is used for measuring/controlling the pH, ORP or NH₃ (ammonia) concentration. The function is switchable on the device itself. Depending on the measured variable, combination electrodes (e. g. pH/redox combination electrodes, gas-sensitive sensors) or split versions (glass/metal electrodes with a separate reference electrode) can be readily connected. Temperature serves as the second input variable, measured by a Pt100/1000, for example. It is therefore possible to implement automatic temperature compensation for the pH and NH₃ variables.

The devices are operated using unambiguous keys and a large LC graphics display on which the measurements are clearly legible. The plain-text presentation of the parameters makes it easier for the user to configure the device, and also helps in programming it correctly.

Thanks to its modular design, the device can be perfectly matched to the specific application requirements. Up to four outputs are available (see the block diagram for the functions).

Typical areas of application

Universal application in water and wastewater engineering, service/process water and wastewater, drinking water and well/surface water, leakage monitoring in refrigeration plant



Type 202560

Block diagram

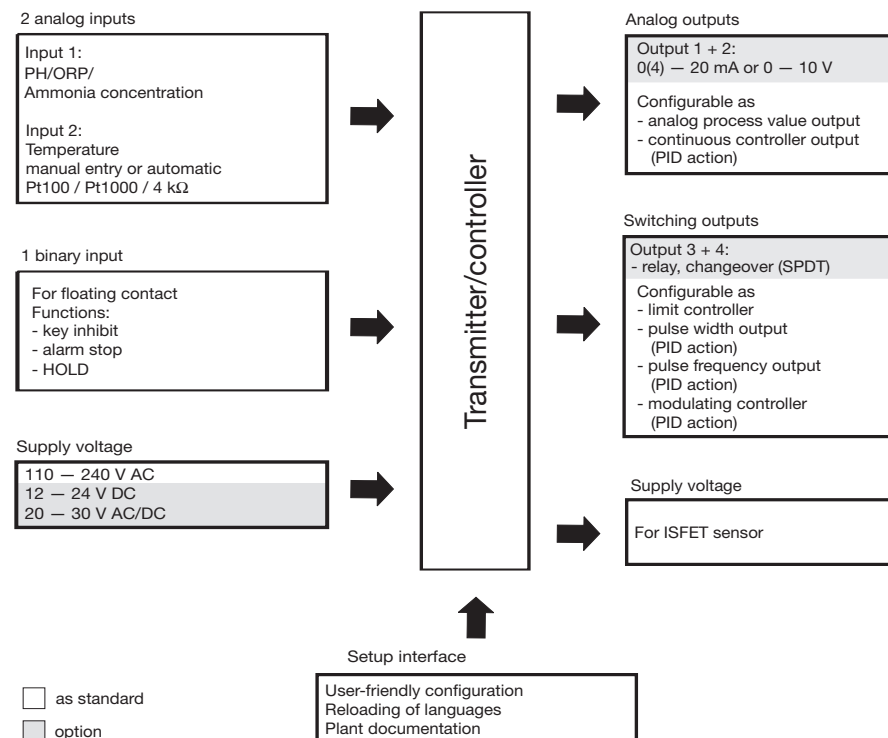

Key features

- Directly switchable to pH, ORP or NH₃ (ammonia) concentration
- Automatic temperature compensation
- Large LC graphics display with background lighting
- Choice of display mode: large numbers, bar graph or trend display
- Solder-free connection system
- Calibration options according to measured variable: 1-/2-/3-point calibration
- Calibration logbook
- Impedance measurement can be activated for pH measurement
- Symmetrical and asymmetrical connection of pH sensors
- pH-ISFET sensors can be connected thanks to the sensor supply integrated in the output
- IP67 protection (in surface mountable housing) IP65 protection (for panel mounting)
- Language changeover: German, English, French; further languages can be loaded through the setup program
- Using the setup program: user-friendly programming, plant documentation, additional languages can be loaded

Approvals



JUMO GmbH & Co. KG
 Delivery address: Mackenrodtstraße 14
 36039 Fulda, Germany
 Postal address: 36035 Fulda, Germany
 Phone: +49 661 6003-0
 Fax: +49 661 6003-607
 Email: mail@jumo.net
 Internet: www.jumo.net

JUMO Instrument Co. Ltd.
 JUMO House
 Temple Bank, Riverway
 Harlow, Essex CM 20 2DY, UK
 Phone: +44 1279 63 55 33
 Fax: +44 1279 62 50 29
 Email: sales@jumo.co.uk
 Internet: www.jumo.co.uk

JUMO Process Control, Inc.
 6733 Myers Road
 East Syracuse, NY 13057, USA
 Phone: +1 315 437 5866
 Fax: +1 315 437 5860
 Email: info.us@jumo.net
 Internet: www.jumousa.com



Functional description

The device is designed for use on site. A rugged housing protects the electronics and the electrical connections from corrosive environmental conditions (IP67). As an alternative, the device can also be installed in a control panel; it is then protected to IP65 at the front. The electrical connection is made by easy-to-fit pluggable screw terminals.

Displays and controls

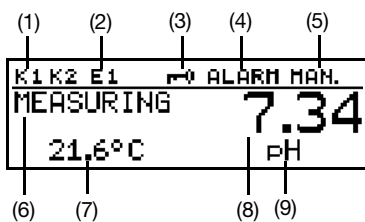

- (1) Switching output 1 or 2 is active
- (2) Binary input 1 has been actuated
- (3) Keypad is inhibited
- (4) Alarm has been activated
- (5) device is in manual mode
- (6) device status
- (7) Temperature of medium
- (8) Principal measurement
- (9) Unit of principal measurement

The user can define what is to be shown in positions (7) and (8) of the display:

- No display
- Compensated measurement
- Temperature
- Output level 1
- Output level 2
- Setpoint 1
- Setpoint 2

Operation

For easy programming and operation, all parameters are arranged in clearly structured levels and shown in plain text. Operation is protected by a code word. This facilitates individual adaptation of the operation, since parameters can be generally enabled or assigned to the protected area.

As an highly convenient alternative to configuration from the keys, the device can also be configured through the setup program for PC (option).

Display modes

Three display modes are available:

Large digits

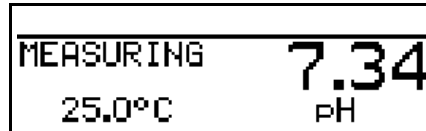

In this display mode, the measurements are, as usual, shown in digits.

Trend display

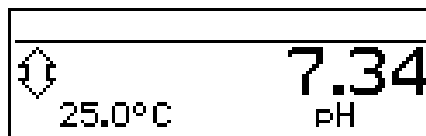

The numerical value is supplemented by a symbol which indicates the change direction and change speed of the measurement. This can, for instance, be very useful during controller tuning.



from left to right:

fast, medium and slow rise, stable, slow, medium and fast drop.

Bar graph

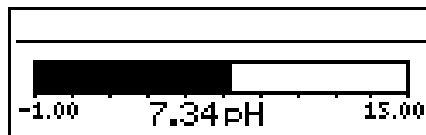

This display mode allows the user to see at a glance in which region the measurement is at present.

The bar graph can be freely scaled.

pH measurement

Both combination pH electrodes and glass electrodes with a separate reference electrode can be connected. There are two ways of connecting the electrodes:

- asymmetrical, high-impedance (this is usual way)
- symmetrical, high-impedance (in special cases)

What is new is the possibility of monitoring the impedance of the connected electrode(s). Thanks to this feature, the glass and reference impedances can be acquired individually (when used with a separate ground pin), or as a cumulative value.

Special electrodes, which use antimony as the pH-sensitive element, can also be connected. A supply for ISFET sensors has been integrated. This enables the user to operate suitable sensors directly.

ISFET sensors are employed for special applications where glass sensors are not required (glass-free pH measurement). However, because these sensors are not standardized, it is necessary to check their usability before application.

The pH is temperature-compensated through automatic temperature measurement, by means of the second input, or by entering the value manually.

ORP measurement

Combination redox electrodes as well as metal electrodes with a separate reference electrode can be connected.

The value is displayed in mV, or is freely scalable.

Ammonia measurement

After the transmitter/controller has been configured for NH₃ (ammonia) measurement, the appropriate sensors can be connected.

Applications:

Leakage monitoring of cooling circuits

Calibration

pH measurement

- 1-point calibration
- 2-point calibration
- 3-point calibration

ORP measurement

- 1-point calibration
- with display in mV
- 2-point calibration with display in % (freely scalable)

NH₃ (ammonia) measurement

- 1-point calibration (zero of electrode)

Calibration logbook

The five most recent calibrations performed successfully can be called up in the calibration logbook. This makes it possible to evaluate the ageing of the sensor that is connected.

If required, the logbook can also be deleted (this makes sense when changing the sensor).

Calibration timer

The calibration timer indicates (if required) when the next routine calibration is due. The calibration timer is activated by entering a number of days, after which recalibration has to be carried out (plant or operator requirement).

Min/Max value memory

This memory acquires the minimum (bottom) or maximum (peak) input variables that have occurred. This information serves, for example, to decide whether the sensor that is connected is designed for the values that are actually present.



Binary input

The following functions can be activated through the binary input:

- Activate key inhibit
 When this function has been activated, operation from the keys is no longer possible.
- Activate HOLD mode
 After activating this function, the outputs (analog and relay) adopt the states that have previously been defined.
- Alarm suppression
 This function temporarily deactivates the alarm generation via the relay (has to be configured accordingly).

Linking the corresponding terminals by means of a floating contact (e. g. relay) will activate the pre-defined function.

Control functions

The relays can have functions assigned that are configured via parameters. The control function is freely programmable as P, PI, PD or PID action.

Relay outputs

One or two relay changeover (SPDT) contacts are available.

The following functions can be programmed:

- Switching direction (min/max)
- Limit controller (pull-in/drop-out delay, hysteresis)
- Pulse width output (see control functions)
- Pulse frequency output (see control functions)
- Modulating controller function (see control functions)
- Limit comparators (pull-in/drop-out delay, hysteresis)
- Pulse function

The output switches on in a defined way when reaching the switching point and then switches off again.

Analog outputs

One or two analog outputs are available. The following functions can be chosen:

Output	Analog process value output		Continuous controller Principle measurement variable
	Principle measurement variable	Temperature	
1	X	-	X
2	-	X	X

With the analog process value output, the range start and end values are freely selectable. The response of the outputs to over/underrange, alarm and calibration is freely programmable. Simulation function:

The analog process value outputs can be freely set in the manual ("Hand") mode.

Application: "Dry-run" start-up of the plant, trouble-shooting, servicing.

- Alarm
- Sensor or range error
- Response to alarm, over/underrange, calibration and HOLD

Contact functions

MAX limit function

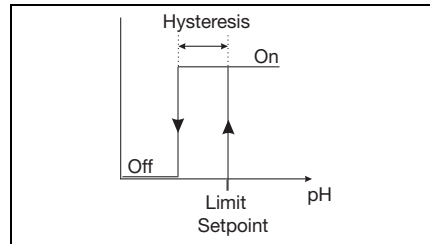

MIN limit function

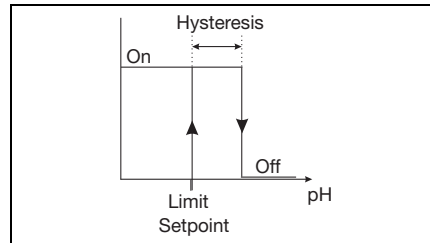

Alarm window 1

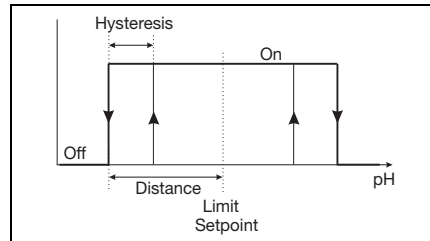

Alarm window 2

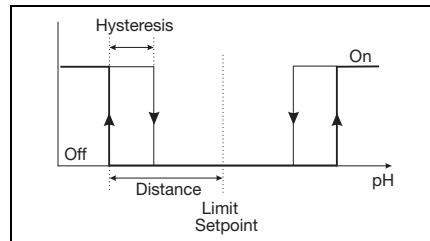

Pulse contact

Trigger condition longer than pulse duration

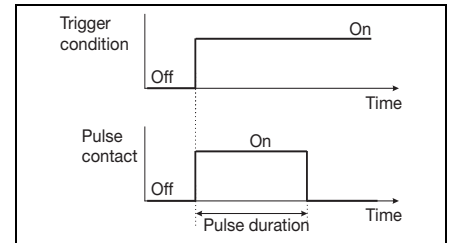

Pulse contact

Trigger condition shorter than pulse duration

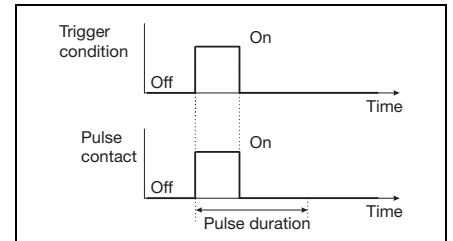

Pulse width controller

(output is active with $X > W$ and P action)

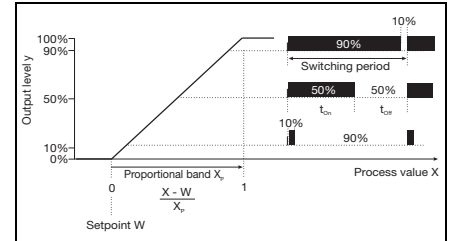

If the process value X exceeds the setpoint W, the P controller will control proportionally to the control deviation. On going outside the proportional band, the controller operates with an output level of 100 % (100 % duty cycle).

Pulse frequency controller

(output is active with $X > W$ and P action)

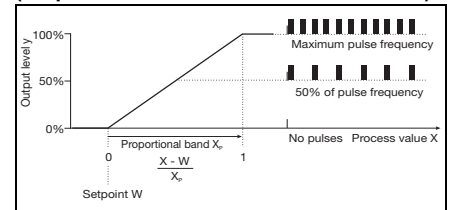

If the process value X exceeds the setpoint W, the P controller will control proportionally to the control deviation. On going outside the proportional band, the controller operates with an output level of 100 % (maximum switching frequency).

JUMO GmbH & Co. KG
 Delivery address: Mackenrodtstraße 14
 36039 Fulda, Germany
 Postal address: 36035 Fulda, Germany
 Phone: +49 661 6003-0
 Fax: +49 661 6003-607
 Email: mail@jumo.net
 Internet: www.jumo.net

JUMO Instrument Co. Ltd.
 JUMO House
 Temple Bank, Riverway
 Harlow, Essex CM 20 2DY, UK
 Phone: +44 1279 63 55 33
 Fax: +44 1279 62 50 29
 Email: sales@jumo.co.uk
 Internet: www.jumo.co.uk

JUMO Process Control, Inc.
 6733 Myers Road
 East Syracuse, NY 13057, USA
 Phone: +1 315 437 5866
 Fax: +1 315 437 5860
 Email: info.us@jumo.net
 Internet: www.jumousa.com



Technical data

Inputs

Principal input	Measurement/control range	Accuracy	Temperature error
pH	-1 to +15 pH	≤ 0.3 %	0.2 %/10 K
ORP	-1500 to +1500 mV	≤ 0.3 %	0.2 %/10 K
NH ₃ (ammonia)	0 to 9999 ppm	≤ 0.3 %	0.2 %/10 K
Secondary input			
Temperature Pt100/1000 (automatic detection)	-50 to +250 °C ^a	≤ 0.5 °C	0.05 %/10 K
Temperature NTC/PTC	4 kΩ max. Entry via table with 20 value pairs	≤ 0.3 % ^b	0.05 %/10 K

^a Switchable to °F.

^b Depending on supporting points.

Temperature compensation

Measurement variable	Compensation	Range ^a
pH	yes	-30 to +150 °C (as of software version 212.11.02) -10 to +150 °C (up to software version 212.11.01)
ORP	no	not applicable
NH ₃ (ammonia)	yes	-20 to +50 °C
pH antimony	yes	-10 to +80 °C

^a Please note operating temperature range of sensor.

Measuring circuit monitoring

Inputs	Over/underrange	Short-circuit	Cable break
pH	yes	yes ^a	yes ^a
ORP	yes	no	no
NH ₃ (ammonia)	yes	no	no
Temperature	yes	yes	yes

^a For pH measurement, the sensor can be monitored for short-circuit and cable break by activating the impedance measurement.

Impedance measurement

Impedance measurement can optionally be activated.

Since it depends on some marginal parameters, the following points must be noted:

- Only glass-based sensors are permissible.
- The sensors must be directly connected to the transmitter.
It is not permissible to use an impedance converter in the measuring circuit.
- The maximum permissible cable length between sensor and transmitter is 10 m.
- Liquid impedances will directly influence the measurement result.

We therefore recommend activating the measurement in liquids from about 100 µS/cm upwards.

Binary input

Activation	Through floating contact
Function	Key inhibit HOLD Alarm suppression

JUMO GmbH & Co. KG
 Delivery address: Mackenrodtstraße 14
 36039 Fulda, Germany
 Postal address: 36035 Fulda, Germany
 Phone: +49 661 6003-0
 Fax: +49 661 6003-607
 Email: mail@jumo.net
 Internet: www.jumo.net

JUMO Instrument Co. Ltd.
 JUMO House
 Temple Bank, Riverway
 Harlow, Essex CM 20 2DY, UK
 Phone: +44 1279 63 55 33
 Fax: +44 1279 62 50 29
 Email: sales@jumo.co.uk
 Internet: www.jumo.co.uk

JUMO Process Control, Inc.
 6733 Myers Road
 East Syracuse, NY 13057, USA
 Phone: +1 315 437 5866
 Fax: +1 315 437 5860
 Email: info.us@jumo.net
 Internet: www.jumousa.com



Controller

Controller type	Limit comparators, limit controller, pulse width controller, pulse frequency controller, modulating controller, continuous controller
Controller action	P / PI / PD / PID
A/D converter	Dynamic resolution up to 14-bit
Sampling time	500 msec

Analog outputs (one or two)

Output mode	Signal range	Accuracy	Temperature error	Permissible load resistance
Current signal	0/4 to 20 mA	≤ 0.25 %	0.08 %/10 K	≤ 500 Ω
Voltage signal	0 to 10 V	≤ 0.25 %	0.08 %/10 K	≥ 500 Ω

The analog outputs respond as per NAMUR NE43 recommendation.
 They are electrically isolated, AC 30 V / DC 50 V.

Switching outputs (two changeover (SPDT) max.)

Rated load	3 A/250 VAC (resistive load)
Contact life	>2x10 ⁵ operations at rated load

Supply for ISFET

DC ±5 V; 5 mA

Setup interface

Interface for configuring the device through the optionally available setup program (for device configuration only).

Electrical data

Supply voltage	AC 110 to 240 V, -15/+10 %, 48 to 63 Hz AC/DC 20 to 30 V, 48 to 63 Hz DC 12 to 24 V, +/-15 % (permissible only for connection to SELV/PELV circuits)
Power consumption	approx. 14 VA
Electrical safety	EN 61 010, Part 1 overvoltage category III ^a , pollution degree 2
Data backup	EEPROM
Electrical connection	pluggable screw terminals conductor cross-section up to 2.5 mm ² (supply, relay outputs, sensor inputs) conductor cross-section up to 1.5 mm ² (analog outputs; ISFET supply)

^a Not valid with protective extra-low voltage of power supply variant 12 to 24 V DC.

Housing

Material	ABS
Cable entry	cable glands, 3 × M16 and 2 × M12 max.
Special feature	venting device to prevent condensation
Ambient temperature range (the accuracy specified is adhered to within this range)	-10 to +50 °C
Operating temperature range (device is operational)	-15 to +65 °C
Storage temperature range	-30 to +70 °C
Climatic conditions	rel. humidity ≤ 90 % annual mean, no condensation (following EN 60721 3-3 3K3)
Enclosure protection as per EN 60529	in surface mountable housing: IP67 for panel mounting: IP65 front, IP20 rear
Vibration strength	as per EN 60068-2-6
Weight	in surface mountable housing: approx. 900 g for panel mounting: approx. 480 g
Dimensions	see dimensioned drawings on page 8.

JUMO GmbH & Co. KG

Delivery address: Mackenrodtstraße 14
 36039 Fulda, Germany
 Postal address: 36035 Fulda, Germany
 Phone: +49 661 6003-0
 Fax: +49 661 6003-607
 Email: mail@jumo.net
 Internet: www.jumo.net

JUMO Instrument Co. Ltd.

JUMO House
 Temple Bank, Riverway
 Harlow, Essex CM 20 2DY, UK
 Phone: +44 1279 63 55 33
 Fax: +44 1279 62 50 29
 Email: sales@jumo.co.uk
 Internet: www.jumo.co.uk

JUMO Process Control, Inc.

6733 Myers Road
 East Syracuse, NY 13057, USA
 Phone: +1 315 437 5866
 Fax: +1 315 437 5860
 Email: info.us@jumo.net
 Internet: www.jumousa.com

**Standard accessories**

Cable glands
 Internal mounting material
 Operating Instructions

Approvals/marks of conformity

Mark of conformity	Testing laboratory	Certificates/certification numbers	Test basis	valid for
c UL us	Underwriters Laboratories	E 201387	UL 61010-1	all types

JUMO GmbH & Co. KG
 Delivery address: Mackenrodtstraße 14
 36039 Fulda, Germany
 Postal address: 36035 Fulda, Germany
 Phone: +49 661 6003-0
 Fax: +49 661 6003-607
 Email: mail@jumo.net
 Internet: www.jumo.net

JUMO Instrument Co. Ltd.
 JUMO House
 Temple Bank, Riverway
 Harlow, Essex CM 20 2DY, UK
 Phone: +44 1279 63 55 33
 Fax: +44 1279 62 50 29
 Email: sales@jumo.co.uk
 Internet: www.jumo.co.uk

JUMO Process Control, Inc.
 6733 Myers Road
 East Syracuse, NY 13057, USA
 Phone: +1 315 437 5866
 Fax: +1 315 437 5860
 Email: info.us@jumo.net
 Internet: www.jumousa.com



Connection diagram

The connection diagram in the data sheet provides preliminary information about the connection options. For the electrical connection, only use the installation instructions or the operating manual. The knowledge and the correct technical execution of the safety information/instructions contained in these documents are mandatory for mounting, electrical connection, startup, and for safety during operation.

The electrical connection for the “in surface mountable housing” version can be made easily after opening the unit.

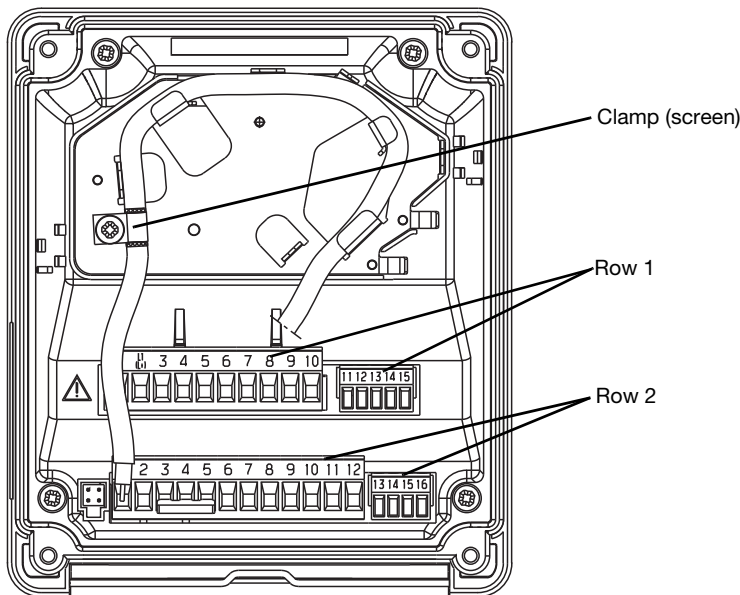
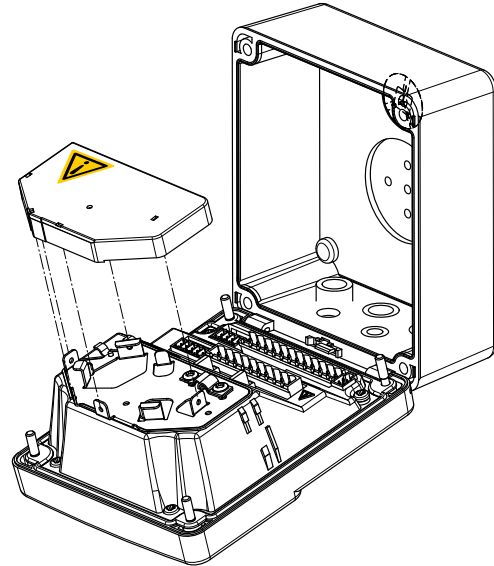

The connection cable between sensor and transmitter must be a special coaxial cable with a diameter of 3 to 5 mm (e. g. type 202990/02-92-(x)-00). The device contains a guide plate for optimized cable routing. The sensor cables (incorporating strain relief) are run to the pluggable screw terminals, where they are connected up without the use of solder.

Connection		Terminal	Function	Row
Supply for transmitter/controller				
Supply voltage (23): AC 110 to 230 V, -15/+10%, 48 to 63 Hz		1	N (L-)	1
Supply voltage (25): AC/DC 20 to 30 V, 48 to 63 Hz		2	L1 (L+)	
Supply voltage (30): DC 12 to 24 V, +/-15%				
NC		3		
Supply voltage for ISFET sensor				
Supply voltage ± 5 V DC, 5 mA		11	L+	1
		12	⊥	
		13	L-	
NC		14		
NC		15		

JUMO GmbH & Co. KG
 Delivery address: Mackenrodtstraße 14
 36039 Fulda, Germany
 Postal address: 36035 Fulda, Germany
 Phone: +49 661 6003-0
 Fax: +49 661 6003-607
 Email: mail@jumo.net
 Internet: www.jumo.net

JUMO Instrument Co. Ltd.
 JUMO House
 Temple Bank, Riverway
 Harlow, Essex CM 20 2DY, UK
 Phone: +44 1279 63 55 33
 Fax: +44 1279 62 50 29
 Email: sales@jumo.co.uk
 Internet: www.jumo.co.uk

JUMO Process Control, Inc.
 6733 Myers Road
 East Syracuse, NY 13057, USA
 Phone: +1 315 437 5866
 Fax: +1 315 437 5860
 Email: info.us@jumo.net
 Internet: www.jumousa.com



Connection		Terminal	Function	Row
Inputs				
Glass/metal electrode		1		2
NC		2		
Reference electrode		3		
NC		4		
GND		5		
Link terminal 3 and terminal 5 (asymmetrical connection only)		6		
FP (liquid potential) For connection with symmetrical connection only		7		
NC		8		
RTD in 3-wire circuit, Pt100 or Pt1000		8 9 10		
Binary input		11 12		
Outputs				
Analog output 1 0 to 20 mA or 20 to 0 mA or 4 to 20 mA or 20 to 4 mA or 0 to 10 V or 10 to 0 V (electrically isolated)		+ 13 - 14		2
Analog output 2 0 to 20 mA or 20 to 0 mA or 4 to 20 mA or 20 to 4 mA or 0 to 10 V or 10 to 0 V (electrically isolated)		+ 15 - 16		
Switching output K1 (floating)		4 5 6	common break (SPST-NC) make (SPST-NO)	1
NC		7		
Switching output K2 (floating)		8 9 10	common break (SPST-NC) make (SPST-NO)	

JUMO GmbH & Co. KG
 Delivery address: Mackenrodtstraße 14
 36039 Fulda, Germany
 Postal address: 36035 Fulda, Germany
 Phone: +49 661 6003-0
 Fax: +49 661 6003-607
 Email: mail@jumo.net
 Internet: www.jumo.net

JUMO Instrument Co. Ltd.
 JUMO House
 Temple Bank, Riverway
 Harlow, Essex CM 20 2DY, UK
 Phone: +44 1279 63 55 33
 Fax: +44 1279 62 50 29
 Email: sales@jumo.co.uk
 Internet: www.jumo.co.uk

JUMO Process Control, Inc.
 6733 Myers Road
 East Syracuse, NY 13057, USA
 Phone: +1 315 437 5866
 Fax: +1 315 437 5860
 Email: info.us@jumo.net
 Internet: www.jumousa.com



Dimensions

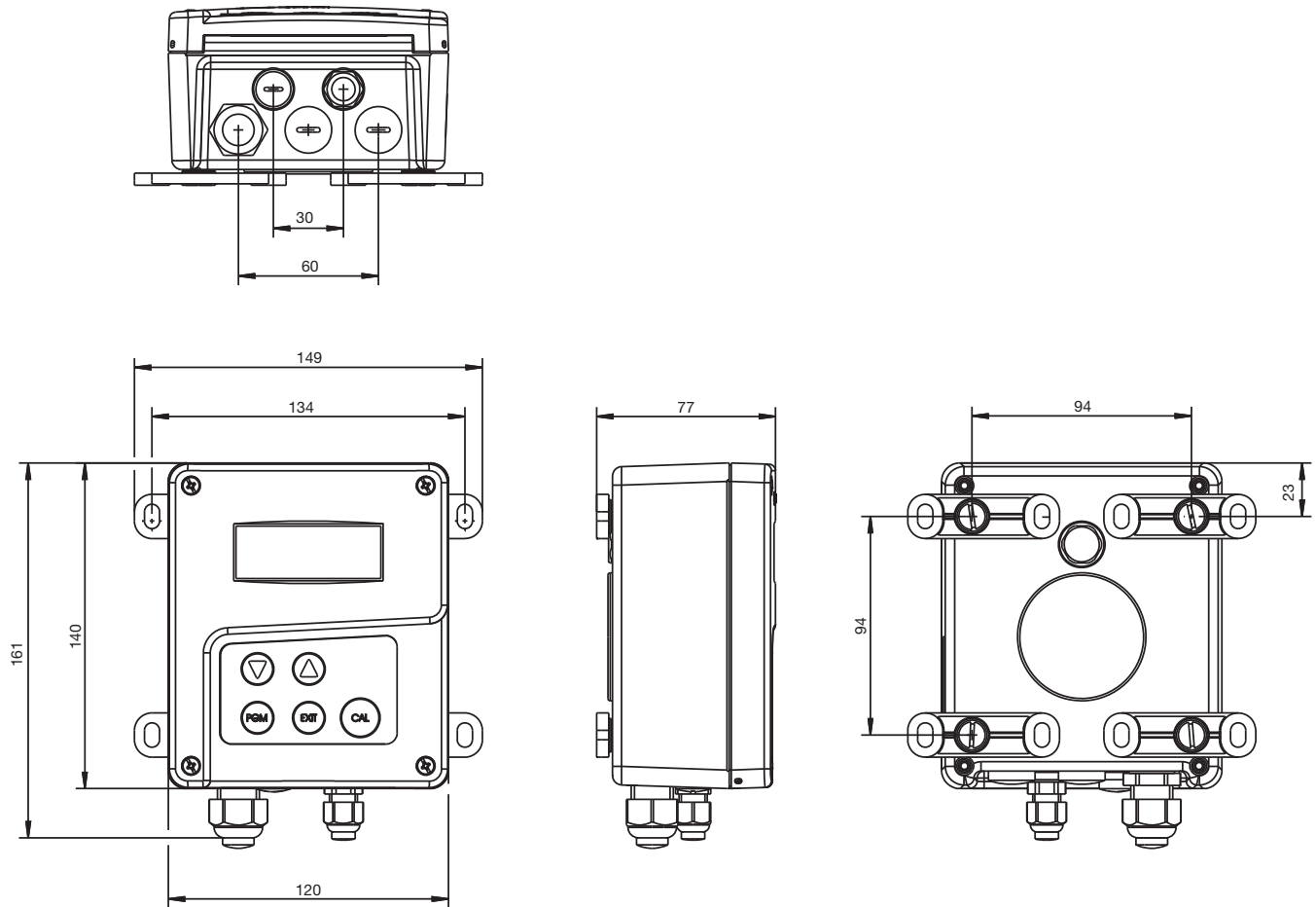

Panel-mounting/drilling diagram

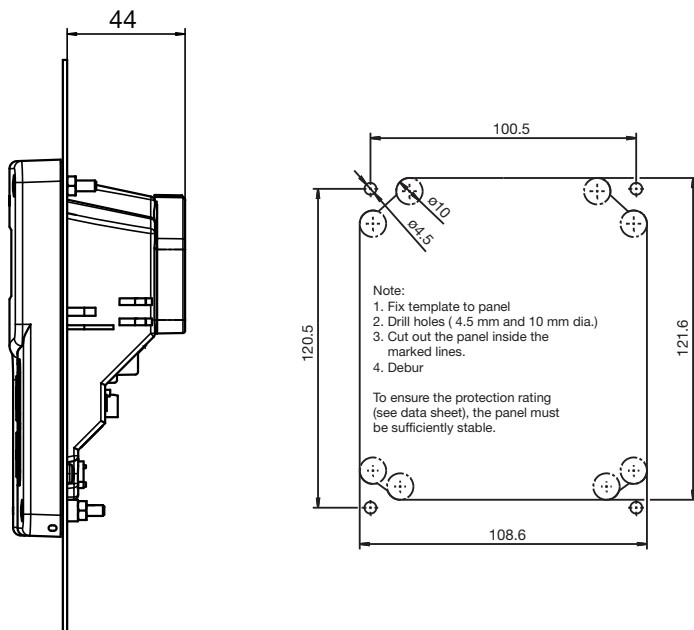

Note:
 The drilling template (in actual size) is shown in the Operating Instructions.

JUMO GmbH & Co. KG
Delivery address: Mackenrodtstraße 14
36039 Fulda, Germany
Postal address: 36035 Fulda, Germany
Phone: +49 661 6003-0
Fax: +49 661 6003-607
Email: mail@jumo.net
Internet: www.jumo.net

JUMO Instrument Co. Ltd.
JUMO House
Temple Bank, Riverway
Harlow, Essex CM 20 2DY, UK
Phone: +44 1279 63 55 33
Fax: +44 1279 62 50 29
Email: sales@jumo.co.uk
Internet: www.jumo.co.uk

JUMO Process Control, Inc.
6733 Myers Road
East Syracuse, NY 13057, USA
Phone: +1 315 437 5866
Fax: +1 315 437 5860
Email: info.us@jumo.net
Internet: www.jumousa.com



Accessories

JUMO AQUIS 500

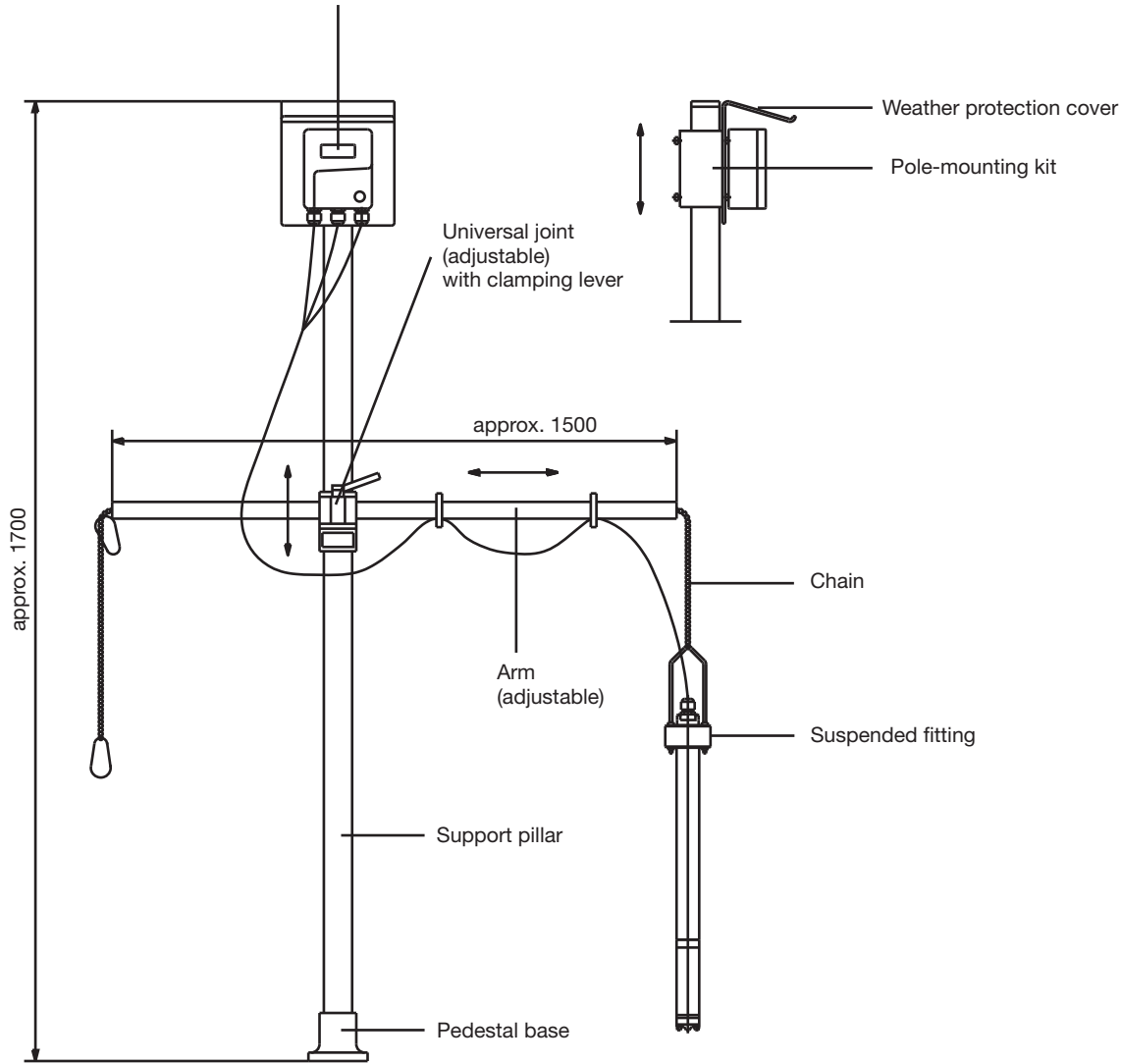

JUMO GmbH & Co. KG
 Delivery address: Mackenrodtstraße 14
 36039 Fulda, Germany
 Postal address: 36035 Fulda, Germany
 Phone: +49 661 6003-0
 Fax: +49 661 6003-607
 Email: mail@jumo.net
 Internet: www.jumo.net

JUMO Instrument Co. Ltd.
 JUMO House
 Temple Bank, Riverway
 Harlow, Essex CM 20 2DY, UK
 Phone: +44 1279 63 55 33
 Fax: +44 1279 62 50 29
 Email: sales@jumo.co.uk
 Internet: www.jumo.co.uk

JUMO Process Control, Inc.
 6733 Myers Road
 East Syracuse, NY 13057, USA
 Phone: +1 315 437 5866
 Fax: +1 315 437 5860
 Email: info.us@jumo.net
 Internet: www.jumousa.com



Order details: JUMO AQUIS 500 pH

(1) Basic type	
202560	JUMO AQUIS 500 pH Transmitter/controller for pH, ORP, NH ₃ (ammonia) concentration and temperature
(2) Basic type extensions	
10	for panel mounting
20	in surface mountable housing
(3) Output 1 (for principle measurement variable or continuous controller)	
000	no output
888	analog output 0(4) to 20 mA or 0(2) to 10 V
(4) Output 2 (for principle measurement variable or continuous controller)	
000	no output
888	analog output 0(4) to 20 mA or 0(2) to 10 V
(5) Output 3	
000	no output
310	relay with changeover (SPDT) contact
(6) Output 4	
000	no output
310	relay with changeover (SPDT) contact
(7) Supply voltage	
23	AC 110 to 240 V + 10 %/-15 %, 48 to 63 Hz
25	AC/DC 20 to 30 V, 48 to 63 Hz
30	DC 12 to 24 V ± 15 %
(8) Extra codes	
000	none

Order code (1) (2) (3) (4) (5) (6) (7) (8)
 Order example / - - - / - / , ...²
 202560 / 20 - 888 - 000 - 310 / 000 - 23 / 000

JUMO GmbH & Co. KG

Delivery address: Mackenrodtstraße 14
36039 Fulda, Germany
Postal address: 36035 Fulda, Germany
Phone: +49 661 6003-0
Fax: +49 661 6003-607
Email: mail@jumo.net
Internet: www.jumo.net

JUMO Instrument Co. Ltd.

JUMO House
Temple Bank, Riverway
Harlow, Essex CM 20 2DY, UK
Phone: +44 1279 63 55 33
Fax: +44 1279 62 50 29
Email: sales@jumo.co.uk
Internet: www.jumo.co.uk

JUMO Process Control, Inc.

6733 Myers Road
East Syracuse, NY 13057, USA
Phone: +1 315 437 5866
Fax: +1 315 437 5860
Email: info.us@jumo.net
Internet: www.jumousa.com



Stock versions

Type	Part no.
202560/20-888-888-310-310-23/000	00480051
202560/20-888-000-310-000-23/000	00480050

Manufactured versions

Type	Part no.
202560/10-888-888-310-310-23/000	00480048
202560/10-888-000-310-000-23/000	00480044
202560/20-888-888-310-310-25/000 ¹	00480049

Accessories

Type	Part no.
Protective roof for JUMO AQUIS 500 ^a	00398161
Pipe installation set for JUMO AQUIS 500 ^b	00483664
DIN rail installation set for JUMO AQUIS 500 ^c	00477842
Support pillar with base clamp, arm and chain	00398163
Holder for suspension fitting	00453191
Back panel set 202560/65	00506351
PC setup software	00483602
PC interface cable including USB/TTL converter and two adapters (USB connecting cable)	00456352

^a The pole-mounting kit is needed for mounting the protection cover.

^b With the pipe installation set, the JUMO AQUIS 500 can be attached to a pipe (e. g. a support pillar or a railing).

^c With the DIN rail installation set, the JUMO AQUIS 500 can be attached to a 35 mm × 7.5 mm DIN rail as per EN 60715 A.1.