

# JUMO dTRANS T1000

## Temperature sensor with IO-Link



Use  **IO-Link**  
Universal · Smart · Easy



Operating Manual



90291500T90Z001K000

V3.00/EN/00656441/2022-10-26

The basic principles of IO-Link are available on the website [www.IO-Link.com](http://www.IO-Link.com)

<b>1</b>	<b>Introduction</b>	<b>5</b>
1.1	Safety information	5
1.2	Description and intended use	6
1.3	Hot media	6
1.4	Hazardous materials	6
1.5	Approvals	7
1.6	Display and connection elements	7
1.7	Dimensions	8
<b>2</b>	<b>Identifying the device version</b>	<b>12</b>
2.1	Nameplate	12
2.2	Order details	14
2.3	Scope of delivery	15
2.4	Accessories	15
<b>3</b>	<b>Mounting</b>	<b>16</b>
<b>4</b>	<b>Electrical connection</b>	<b>17</b>
4.1	Connection examples	18
<b>5</b>	<b>Configuration</b>	<b>19</b>
<b>6</b>	<b>Functions</b>	<b>20</b>
6.1	Switching points	20
6.1.1	Hysteresis function	21
6.1.2	Window function	22
6.1.3	Switch-on delay/switch-off delay	23
6.2	Fine adjustment	24
6.3	Teach functions	26
6.4	Fault signaling	27
<b>7</b>	<b>Parameter overview</b>	<b>29</b>
7.1	Process data	29
7.2	Configuration data	30
7.3	Service data	33
<b>8</b>	<b>Technical data</b>	<b>34</b>
8.1	Input	34

---

# Contents

---

8.2	Output . . . . .	35
8.3	Interface . . . . .	35
8.4	Electrical data . . . . .	36
8.5	Mechanical features . . . . .	36
8.6	Environmental influences . . . . .	37
<b>9</b>	<b>China RoHS . . . . .</b>	<b>38</b>

## 1.1 Safety information

### General

This manual contains information that must be observed in the interest of your own safety and to avoid material damage. This information is supported by symbols which are used in this manual as indicated.

Please read this manual before starting up the device. Store this manual in a place that is accessible to all users at all times.

If difficulties occur during startup, please do not intervene in any way that could jeopardize your warranty rights!

### Warning symbols



#### CAUTION!

This symbol in connection with the signal word indicates that **material damage or data loss** will occur if the respective precautionary measures are not taken.

---



#### READ THE DOCUMENTATION!

This symbol, which is attached to the device, indicates that the associated **documentation for the device** must be **observed**. This is necessary to identify the nature of the potential hazard, and to take measures to prevent it.

---

### Note symbols



#### NOTE!

This symbol refers to **important information** about the product, its handling, or additional benefits.

---



#### REFERENCE!

This symbol refers to **additional information** in other sections, chapters, or other manuals.

---



#### DISPOSAL!

At the end of its service life, the device and any batteries present do not belong in the trash! Please ensure that they are **disposed of** properly and in an **environmentally friendly** manner.

---

# 1 Introduction

---

## 1.2 Description and intended use



### NOTE!

Please read this manual before starting up the device. Store this manual in a place that is accessible to all users at all times.

---

The temperature sensor is used for temperature measurement and monitoring. The effect of the temperature on a resistance RTD temperature probe generates a signal, which is amplified, digitalized and processed.

The temperature sensor is equipped with an IO-Link interface as per specification 1.1. IO-Link supports bidirectional communication and is used to exchange the process data, parameters, diagnostic information and status messages. The two green LEDs are permanently lit as soon as power is supplied to the device. Once an IO-Link connection is established, the LEDs flash.

The switching behavior and the switching thresholds of the switching outputs (max. 2 pcs.; p or n switching) can be individually configured, as can many other parameters. Any IO-Link master can be used for the configuration.

The temperature sensor is thus suitable for use in plant and mechanical engineering in connections to automation systems. Many process connections are available to the user.

The temperature sensor is UL-approved. The approval stipulates use of the temperature sensor indoors only.

**The protection offered by the temperature sensor may be impaired if the temperature sensor is used in a way that does not comply with the manufacturer's intended use.**

## 1.3 Hot media

Hot media may result in the device surfaces becoming hot and presenting a risk of injury.

- Allow the device and plant to cool down.
- Wear suitable protective equipment.
- If required, install contact protection.

## 1.4 Hazardous materials

Using hazardous materials as a medium may result in abrasive and corrosive damage to components of the product that come into contact with the medium. The medium may leak and present a fire hazard and a risk to health.

Carry out a risk assessment taking into consideration the safety data sheet for the relevant hazardous substance for mounting, operation, maintenance, cleaning, and disposal:

- Comparison and systematic checking of the durability of the components of the product that come into contact with the medium and the admissible environmental influences.
- Assessment of the risk to people and the environment.
- Assessment of the fire hazard due to the product materials, the admissible environmental influences, and the voltage supply.

## 1.5 Approvals

	Designation	UL
	Testing agency	-
	Certificate no.	2022-07-27-E201387
	Inspection basis	UL 61010-1, 3 Ed. Mai 2012 revised 19. Juli 2019 und CAN/CSA-C22.2 No. 61010-1 (2012-05). 3. Ed. with revision through 2018-11
	Valid for	Type 902915

## 1.6 Display and connection elements

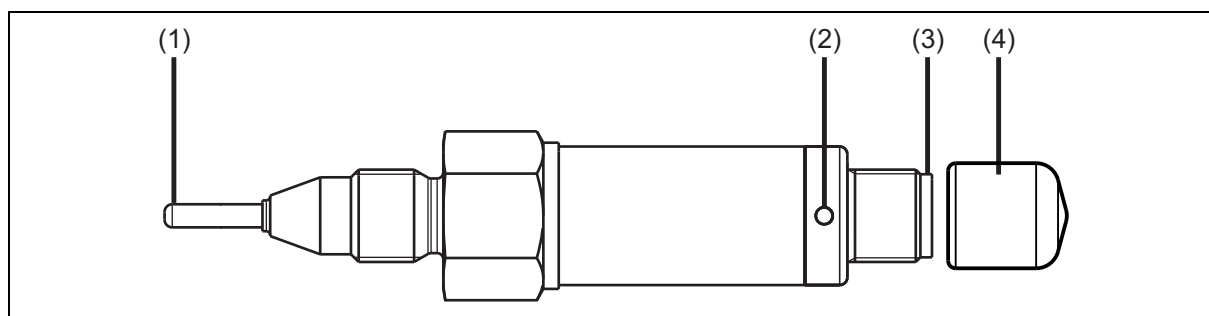

- (1) Protection tube with RTD temperature probe
- (2) Status LED (other identical LEDs opposite)
- (3) M12 connection
- (4) Protective cap for storage and transport

# 1 Introduction

## 1.7 Dimensions

<p>Type 902915/10 and type 902915/30 Without process connection (PA) 000</p>	<p>Type 902915/10 with PA 103-104 (left) Type 902915/30 with PA 103-104 (right)</p>
<p>Type 902915/10 with PA 379</p>	<p>Type 902915/10 with PA 380 (left) Type 902915/30 with PA 380 (right)</p>



# 1 Introduction

Type 902915/10 with PA 550-554 (left)  
Type 902915/30 with PA 550-554 (right)

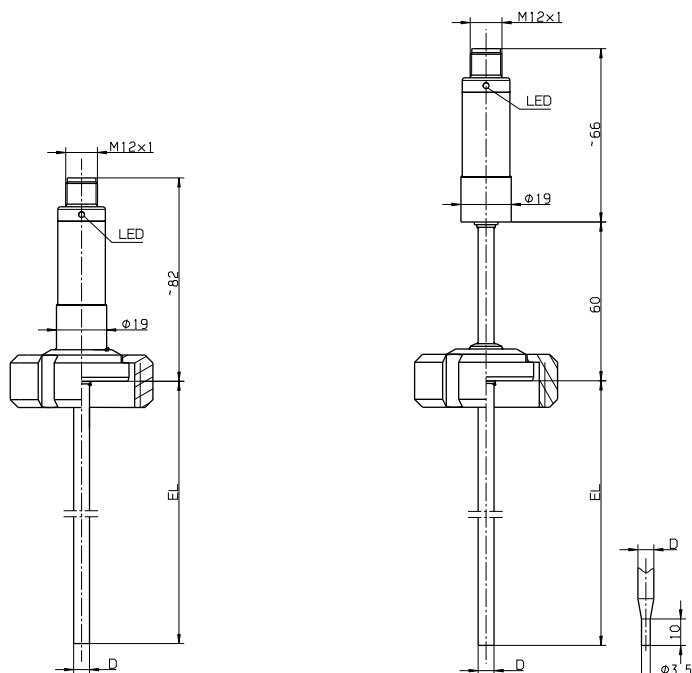

Type 902915/10 with PA 601 (left)  
Type 902915/10 with PA 604-605 (center)  
Type 902915/30 with PA 601-605 (right)

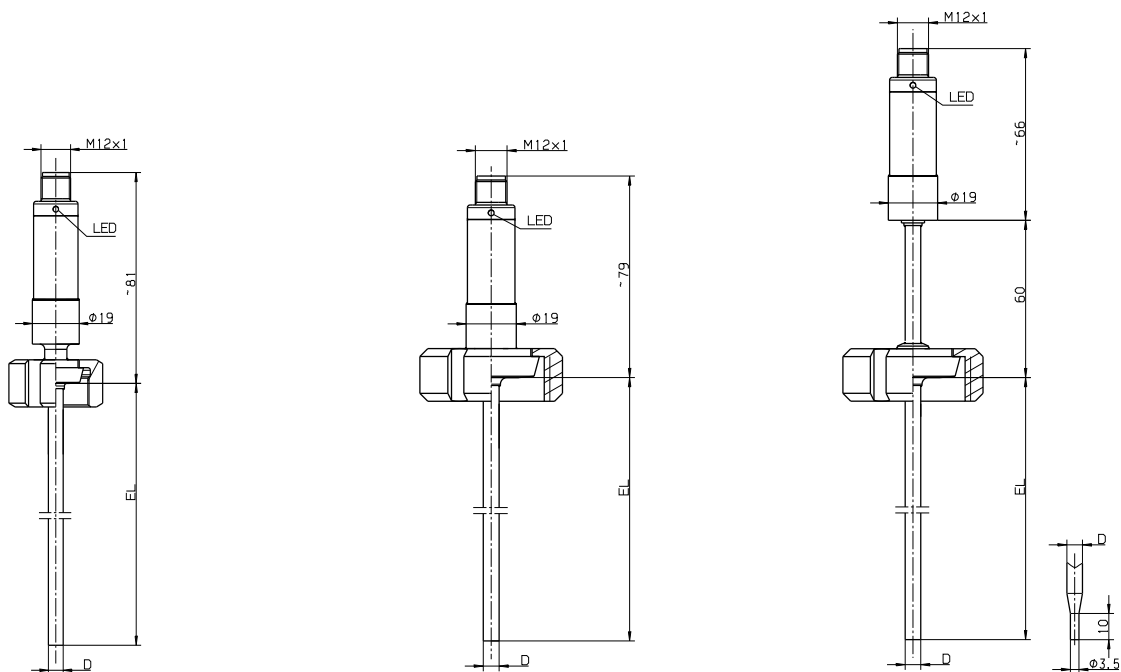

# 1 Introduction

Type 902915/10 with PA 611-617 (left)  
 Type 902915/30 with PA 611-617 (right)

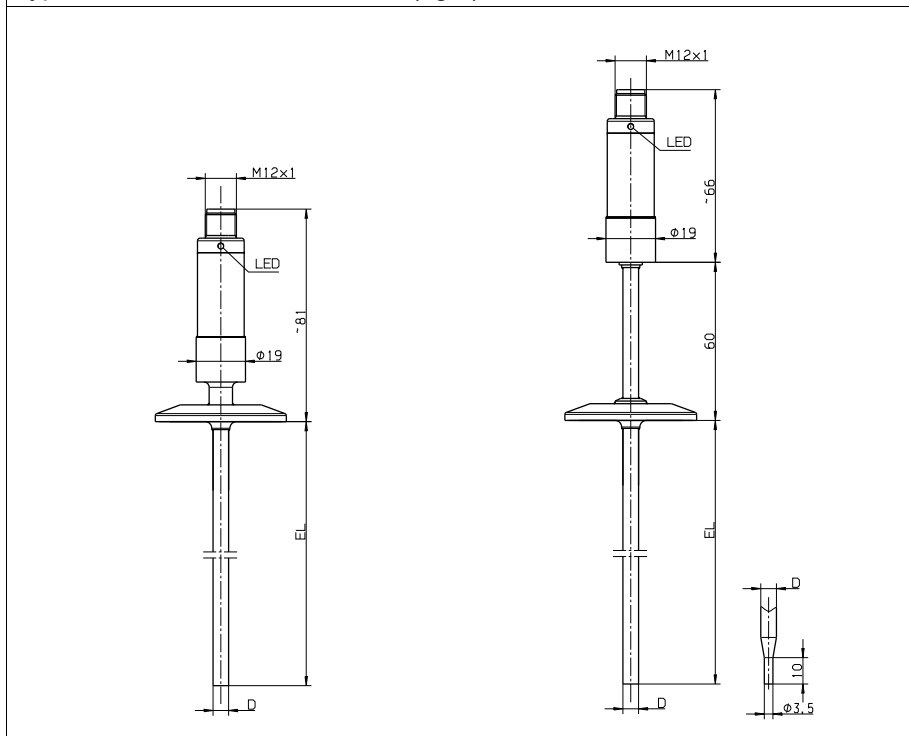

Type 902915/10 with PA 681

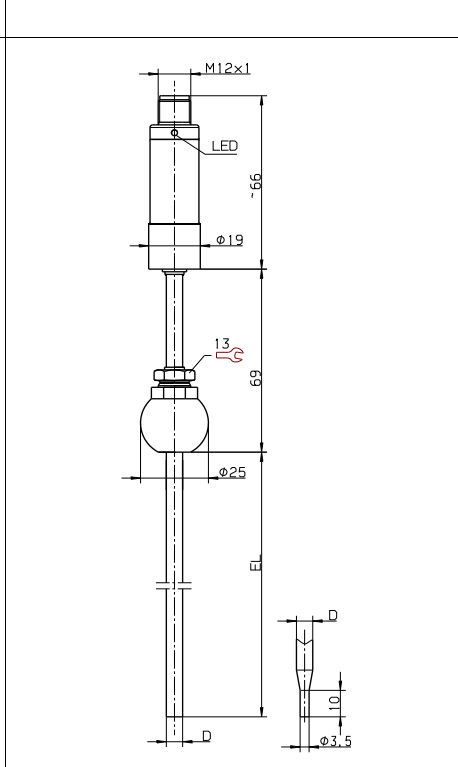

Type 902915/10 with PA 682

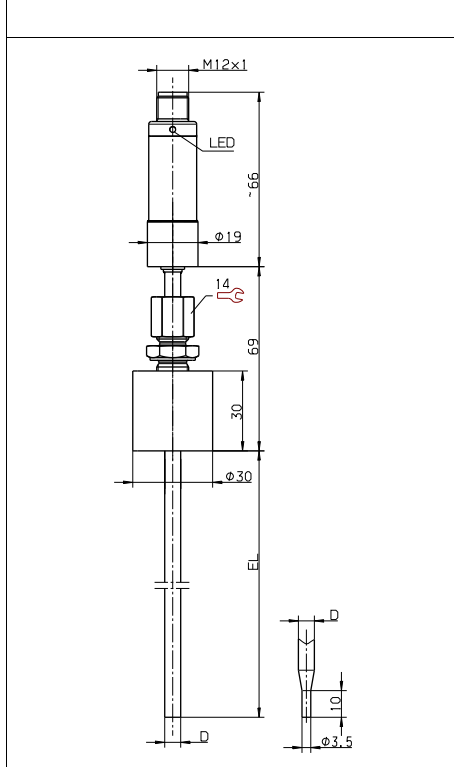

Type 902915/10 with PA 684-686 (left)  
 Type 902915/30 with PA 684-686 (right)

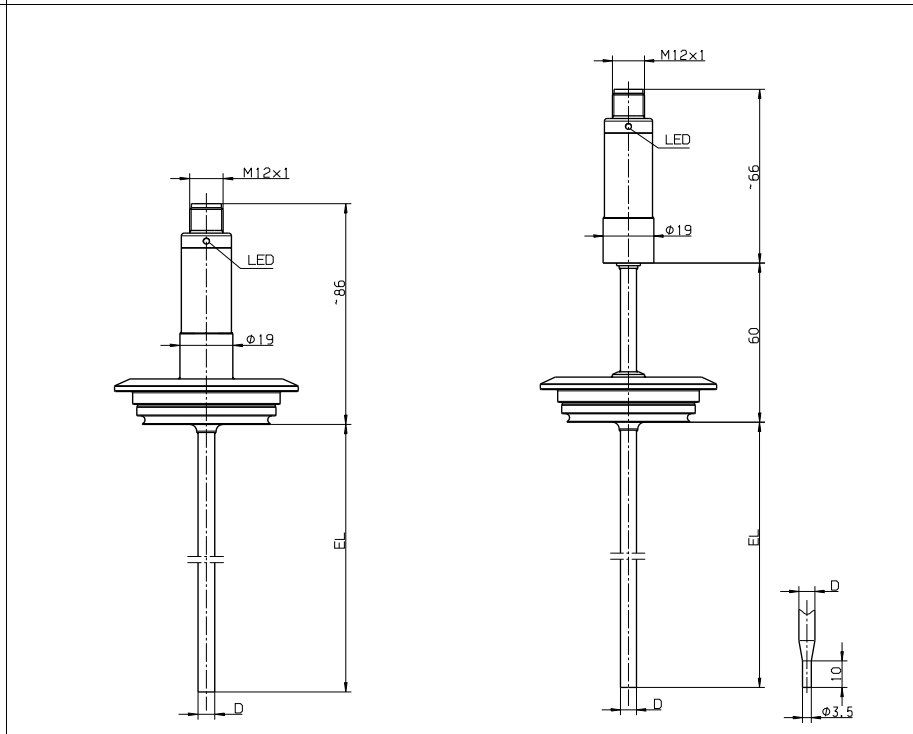

# 1 Introduction

Type 902915/10 with PA 755-758 (left)  
Type 902915/30 with PA 755-758 (right)

Type 902915/30 with PA 997

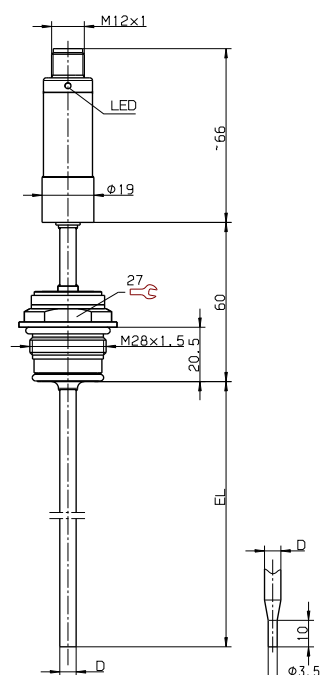
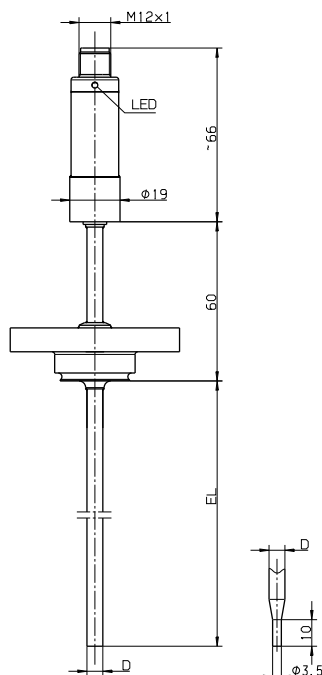
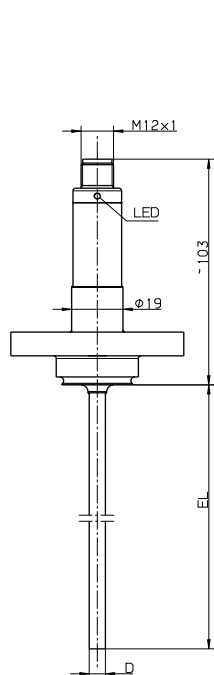

## 2 Identifying the device version

### 2.1 Nameplate

#### Position

The nameplate is located on the housing surface.

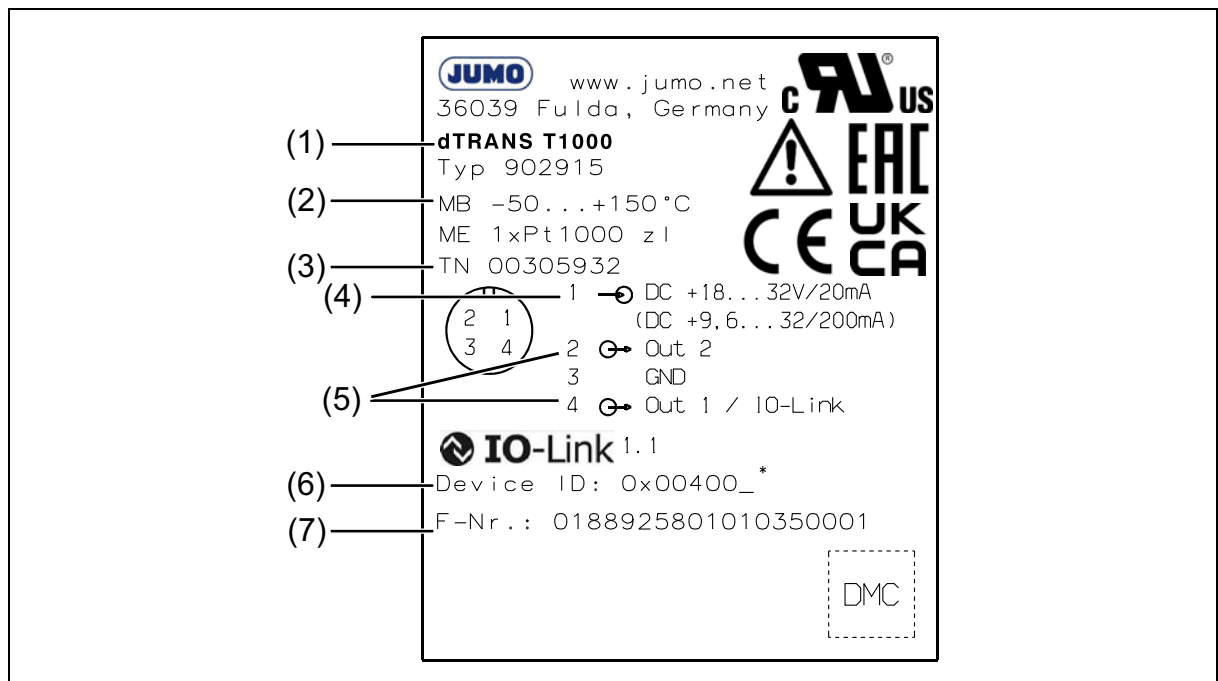

- |                        |  |
|------------------------|--|
| (1) Device name        | (2) Input – nominal measuring range  |
| (3) Part no.           | (4) Voltage supply and maximum current consumption <sup>a</sup><br>⇒ For more in-depth information, see "Technical Data" |
| (5) Outputs            | (6) Device ID  |
| (7) Fabrication number |  |

<sup>a</sup> The specifications outside the brackets „()“ refer to use of the device in IO-Link operation. The specifications inside the brackets „()“ refer to use of the device in switch operation.

#### Part no.

The part no. clearly identifies an article in the catalog. It is important for communication between the customer and the sales department.

#### Device ID

The device ID can help when localizing the device description file (IODD), which can be found on the manufacturer's website and also downloaded if necessary.

#### **Downloading the IODD:**

1. Open the website [www.jumo.de](http://www.jumo.de) (change the language to English if necessary)
2. Use the search function to select the device
3. Under "Software", download the ZIP file containing the collection of IODDs
4. Extract all files from the ZIP folder
5. Use the device ID to locate the IODD and save it

*The IODD is now available for use with the IO-Link master's configuration tool. This can be used to configure and check the device.*

## 2 Identifying the device version

---

Instead of the manufacturer's website, you can also use the address: <http://ioddfinder.io-link.com>.

### **Fabrication number (F-Nr)**

Among other things, the fabrication number indicates the date of manufacture (year/calendar week).

### **Date of manufacture**

The device's date of manufacture (year and calendar week) is part of the fabrication number. Digits 12 to 15 denote the year of manufacture (in this case 17 for 2017) and the calendar week (11 in this case).

## 2 Identifying the device version

### 2.2 Order details

<b>(1) Basic type</b>	
902915	JUMO dTRANS T1000 – Temperature sensor with IO-Link
<b>(2) Basic type extension</b>	
10	IO-Link interface, M12 × 1 connector
30	IO-Link interface, M12 × 1 connector, high-temperature
<b>(3) Operating temperature in °C</b>	
370	-50 to +150 °C
386	-50 to +260 °C
<b>(4) Measuring insert</b>	
1013	1 × Pt1000 in 4-wire circuit
<b>(5) Tolerance class of RTD temperature probe according to DIN EN 60751</b>	
2	Class A
3	Class AA
<b>(6) Protection tube diameter D in mm</b>	
3	3 mm <sup>a</sup>
6	6 mm
<b>(7) Insertion length</b>	
15	15 mm <sup>a</sup>
20	20 mm <sup>a</sup>
25	25 mm <sup>a</sup>
50	50 mm
100	100 mm
150	150 mm
<b>(8) Process connection (PC)</b>	
000	None
103	Screw connection G 3/8
104	Screw connection G 1/2
379	Screw connection M12 x 1.5 with CIP-compliant conical seal
380	Screw connection G 1/2 with CIP-compliant conical seal
550	Aseptic screw connection DN 20 DIN 11864-1 Form A
551	Aseptic screw connection DN 25 DIN 11864-1 Form A
552	Aseptic screw connection DN 32 DIN 11864-1 Form A
553	Aseptic screw connection DN 40 DIN 11864-1 Form A
554	Aseptic screw connection DN 50 DIN 11864-1 Form A
601	Taper socket with union nut DN 10 DIN 11851 (dairy pipe fitting)
604	Taper socket with union nut DN 25 DIN 11851 (dairy pipe fitting)
605	Taper socket with union nut DN 32 DIN 11851 (dairy pipe fitting)
611	Clamping socket (clamp) DN 10/20 DIN 32676
613	Clamping socket (clamp) DN 25/40 DIN 32676
616	Clamping socket (clamp) DN 50 DIN 32676 (2" ISO 2852)
617	Clamping socket (clamp) 2 1/2" similar to DIN 32676
681	Ball welding socket with threaded fitting
682	Welding socket with CIP-compliant conical seal
684	VARIVENT® connection DN 15/10

## 2 Identifying the device version

685	VARIVENT® connection DN 32/25
686	VARIVENT® connection DN 50/40
755	BioControl® D25
756	BioControl® D50
757	BioControl® D65
758	BioControl® D80
997	JUMO PEKA hygienic process connection
<b>(9) Protection tube material</b>	
24	Stainless steel 316L (material no. 1.4404/1.4435)
<b>(10) Extra code</b>	
061	With UL approval
100	Customer-specific configuration (specifications in plain text)
310	Protection tube offset <sup>b</sup>
374	Inspection certificate 3.1 DIN EN 10204 (material)
452	Wetted, electrolytically polished parts, surface roughness $R_a \leq 0.8$ mm
458	Surface roughness $R_a \leq 0.4$ µm for clamping socket (clamp) (area touching medium)
774	DAkkS(DKD) calibration (standard, test points 0, 100 and 200 °C)
775	DAkkS(DKD) calibration (service, please state desired test points in plain text)
974	DAkkS(DKD) adjustment with calibration report (standard, test points 0, 100 and 200 °C)
975	DAkkS(DKD) adjustment with calibration report (service, please state desired test points in plain text)

<sup>a</sup> Only with screw connection M12 x 1.5 with CIP-compliant conical seal (process connection 379)

<sup>b</sup> Not for screw connection M12 x 1.5 with CIP-compliant conical seal (process connection 379)

	(1)	(2)	(3)	(4)	(5)	(6)	(7)	(8)	(9)	(10)									
Order code	<input type="text"/>	/	<input type="text"/>	-	<input type="text"/>	-	<input type="text"/>	-	<input type="text"/>	-	<input type="text"/>	/	<input type="text"/>						
Order example	902915	/	10	-	370	-	1013	-	2	-	3	-	15	-	379	-	24	/	452

### 2.3 Scope of delivery

<b>Designation</b>
1 temperature sensor in the ordered version
1 installation instructions

### 2.4 Accessories

Designation	Part no.
IO-Link master upon request.	
Device data (IODD) at <a href="http://www.jumo.de">www.jumo.de</a> or at <a href="http://ioddfinder.io-link.com">http://ioddfinder.io-link.com</a>	
Welding socket <sup>a</sup> G 1/2 for process connection 380	00378264
Welding socket with collar <sup>a</sup> M12 x 1.5 for process connection 379	00614228
Welding socket <sup>a</sup> M12 x 1.5 for process connection 379	00655051

<sup>a</sup> Welding sockets made of material 1.4404, parts touching the media electrolytically polished, surface roughness  $R_a \leq 0.4$  µm

## 3 Mounting

---

The temperature sensor may only be installed, connected and started up by qualified and authorized personnel observing these operating instructions, the applicable standards, and the legal requirements (depending on the application).

If you experience difficulties during installation and startup, please contact the manufacturer.

The device can be installed in any position.



**NOTE!**

The temperature sensor is not suitable for safety-critical applications.

---



**NOTE!**

The temperature sensor is not suitable for installation and application in potentially explosive areas.

---



**NOTE!**

The temperature sensor must be connected to the potential equalization system of the plant via the process connection.

---



**NOTE!**

Mount the device so that abrasion at the process connection is avoided.



---

### Mounting the sensor

- Insert the temperature sensor into the corresponding drilled hole and tighten it by hand, making sure the profile seal and/or O-ring (if fitted) are sitting correctly
  - Tighten the temperature sensor with a suitable wrench
- ⇒ For the wrench size, see chapter 1.7 "Dimensions", Page 8

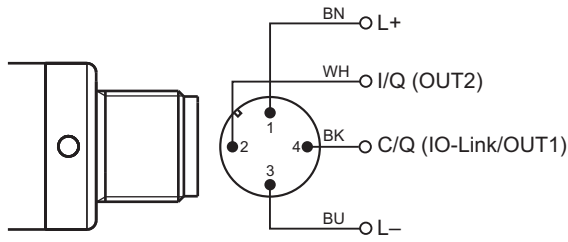

## 4 Electrical connection

Connection	Terminal assignment	
		
	Round plug M12 × 1 (A-coded, non-rotating)	
<b>Switch operation</b>		
Voltage supply <sup>a</sup> DC 9.6 to 32 V	1 BN (brown) <sup>b</sup> 3 BU (blue)	L+ L-
Switching output 1	4 BK (black)	C/Q = OUT1
Switching output 2	2 WH (white)	I/Q = OUT2
<b>IO-Link operation</b>		
Voltage supply <sup>a</sup> DC 18 to 32 V	1 BN (brown) 3 BU (blue)	L+ L-
IO-Link	4 BK (black)	C/Q = IO-Link
Switching output 2	2 WH (white)	I/Q = OUT2
<b>Potential equalization</b>		
Functional bonding conductor FB <sup>c</sup>		

<sup>a</sup> The auxiliary energy of the temperature sensor must meet SELV requirements. Furthermore, the device must be equipped with an electrical circuit that meets the requirements of EN 61010-1 with regard to "Limited-energy circuits".

<sup>b</sup> The colour coding is only valid for A-coded standard cables!

<sup>c</sup> The temperature sensor must be connected to the potential equalization system of the plant via the process connection.



### NOTE!

When using the device with UL approval, the user must make sure that the accessory he uses is also approved for a UL application (e. g. cable with UL approval AVLV2/8 and/or cable with UL approval CYJV/7 or CYJV/8 or PVVA/7 or PVVA2/8, in each case approved for ambient temperatures > 90 °C).

# 4 Electrical connection

## 4.1 Connection examples

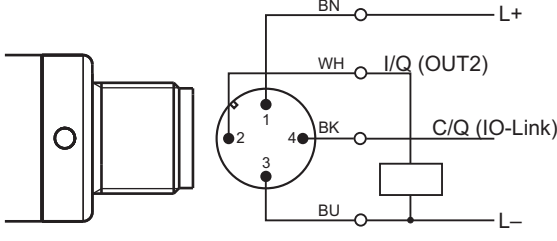
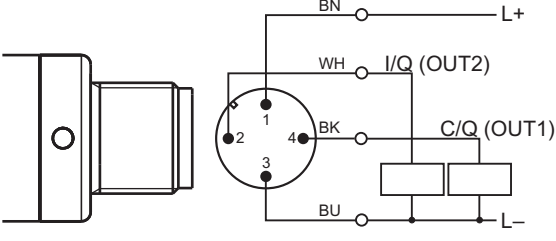
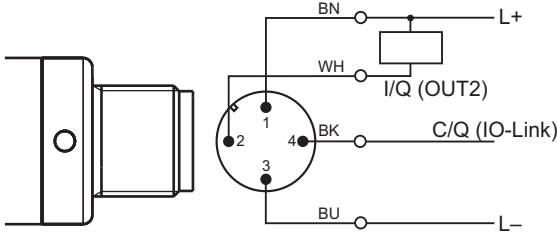
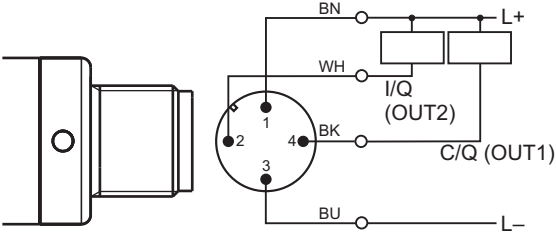
IO-Link operation with 1 switching output	Switch operation with 2 switching outputs
<p>p switching (PNP)</p> 	<p>p switching (PNP)</p> 
<p>n switching (NPN)</p> 	<p>n switching (NPN)</p> 

## Starting up the IO-Link master and configuration tool

If you are using a conventional IO-Link master, you must complete the following steps to configure the sensor.

1. Start up the hardware and software for the IO-Link master
2. Load the sensor's device description file (IODD)
  - a) Open the website [www.jumo.de](http://www.jumo.de) (change the language to English if necessary)
  - b) Use the search function to select the sensor
  - c) Under "Software", download the ZIP file containing the collection of IODDs
  - d) Extract all files from the ZIP folder
3. Start the configuration tool
4. Update the device catalog (import the IODD; localize using the "device ID" on the nameplate or the text file in the IODD collection)
5. Create a new project
6. Establish a connection
7. Configure, extract, monitor, etc., the sensor

Instead of the manufacturer's website, you can also use the address: <http://ioddfinder.io-link.com>.

## Configuration tool (overview)

Depending on the configuration tool, the menu structure contains different areas. The typical structure is listed below:

- Identification and information  
These areas show information on the manufacturer and device as well as general information.
- Parameters  
This section is used to configure the device.
  - General parameters
  - Switching points ⇒ chapter 6.1 "Switching points", Page 20
  - Fine adjustment ⇒ chapter 6.2 "Fine adjustment", Page 24
  - Event settings ⇒ chapter 6.4 "Fault signaling", Page 27
  - Versions
  - Service information
- Monitoring  
In this area process data can be extracted (snapshot).
- Diagnosis and events  
These areas show diagnostic data and information about events.
- Process data  
This area shows the current process data, which is extracted cyclically.

# 6 Functions



## CAUTION!

Write operations to some R/W parameters result in them being saved to the EEPROM. This memory module has only a limited number of write cycles (approx. 100,000).

Frequent writing of certain parameters can therefore result in a memory error.

- ▶ Fast writing cycles should thus be avoided.

## 6.1 Switching points

Depending on the operating mode, the sensor has 1 or 2 switching outputs. It automatically detects the connection type and responds accordingly. Separate parameters are available for both switching outputs.

Operating mode	Output	Pin at the M12 connection
SIO mode (SIO = Standard IO)	Switching output 1	C/Q (OUT1)
	Switching output 2	I/Q (OUT2)
IO-Link mode	IO-Link communication	C/Q (IO-Link)
	Switching output 2	I/Q (OUT2)

### Parameter

Parameter	Selection/settings	Description
Switching behavior	<b>Inactive</b> Hysteresis function, N/O Contact Hysteresis function, N/C Contact Window function, N/O Contact Window function, N/C Contact	When inactive is selected, the selected switching output is not activated.
Switching point (SP) or window high (FH)	-999 to <b>0</b> to +999	The selected switching output is only activated if $rSP < SP$ or $FL < FH$ . ⇒Chapter 6.1.1 ⇒Chapter 6.1.2
Release point (rSP) or window low (FL)	-999 to <b>0</b> to +999	
Switch-on delay (VSP)	<b>0</b> to 100 s	⇒Chapter 6.1.3
Switch-off delay (VrSP)	<b>0</b> to 100 s	
Output driver mode	<b>p-switching</b> n-switching	⇒Chapter 4.1

## 6.1.1 Hysteresis function

The hysteresis function switches the output as soon as the switching point "SP" is reached. When the release point "rSP" is reached, the output switches again.

The hysteresis function distinguishes between N/C and N/O contacts.

Switching requirement: Switching point "SP"  $\geq$  Release point "rSP"

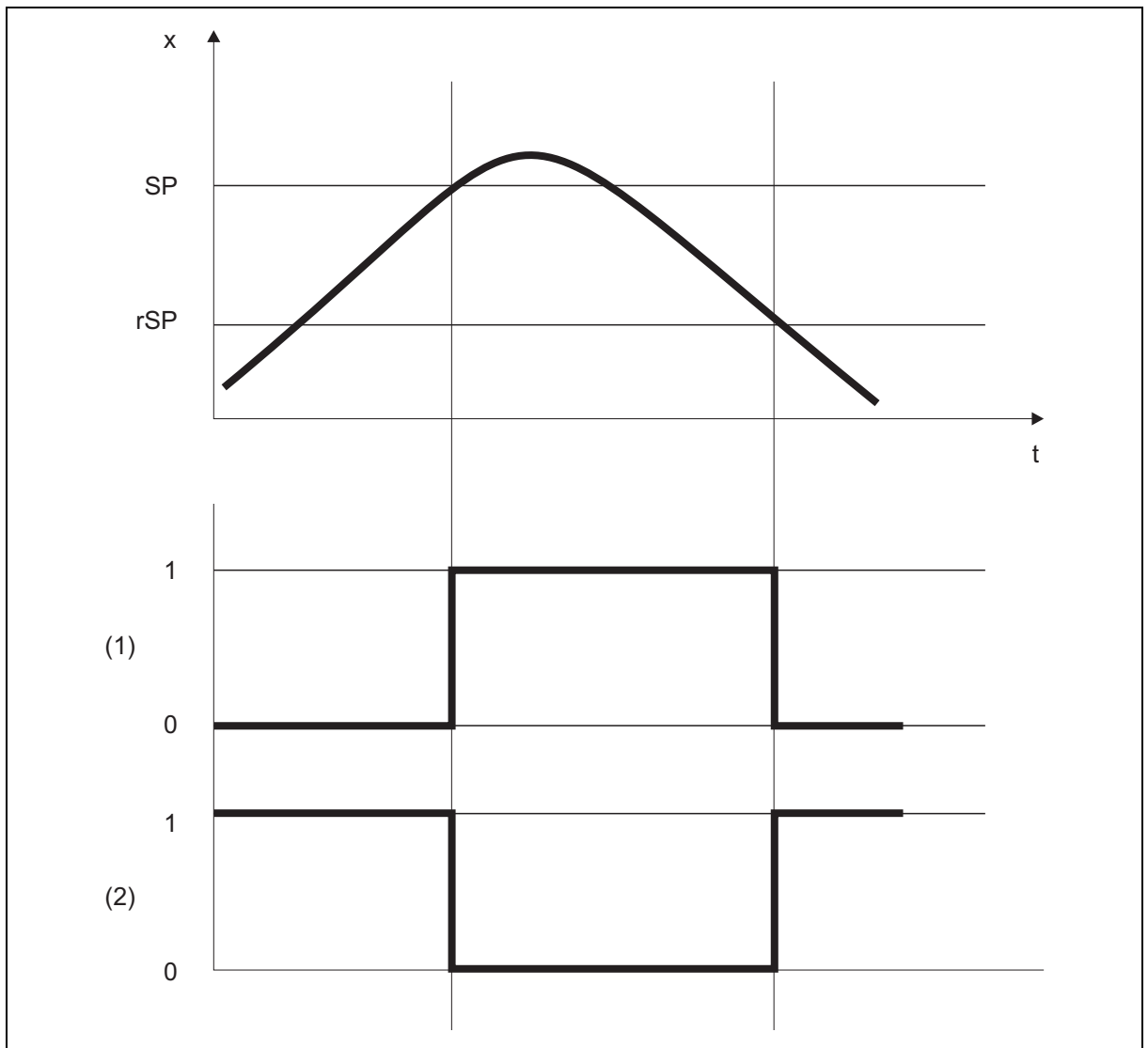

- x = Measured value
- t = Time
- SP = Switching point
- rSP = Release point
- (1) = N/O contact
- (2) = N/C contact

# 6 Functions

## 6.1.2 Window function

Under the window function, the window range is defined using the parameters window low "FL" (lower value) and window high "FH" (upper value). The output switches when the current measured value (x) is between the two limits  $[(x > FL) \& (x < FH)]$ .

The window function distinguishes between N/C and N/O contacts.

Requirement: Window high "FH"  $\geq$  Window low "FL"

The window high "FH" and window low "FL" switching points have a fixed symmetrical hysteresis of  $\pm 0.25\%$  of the measuring range.

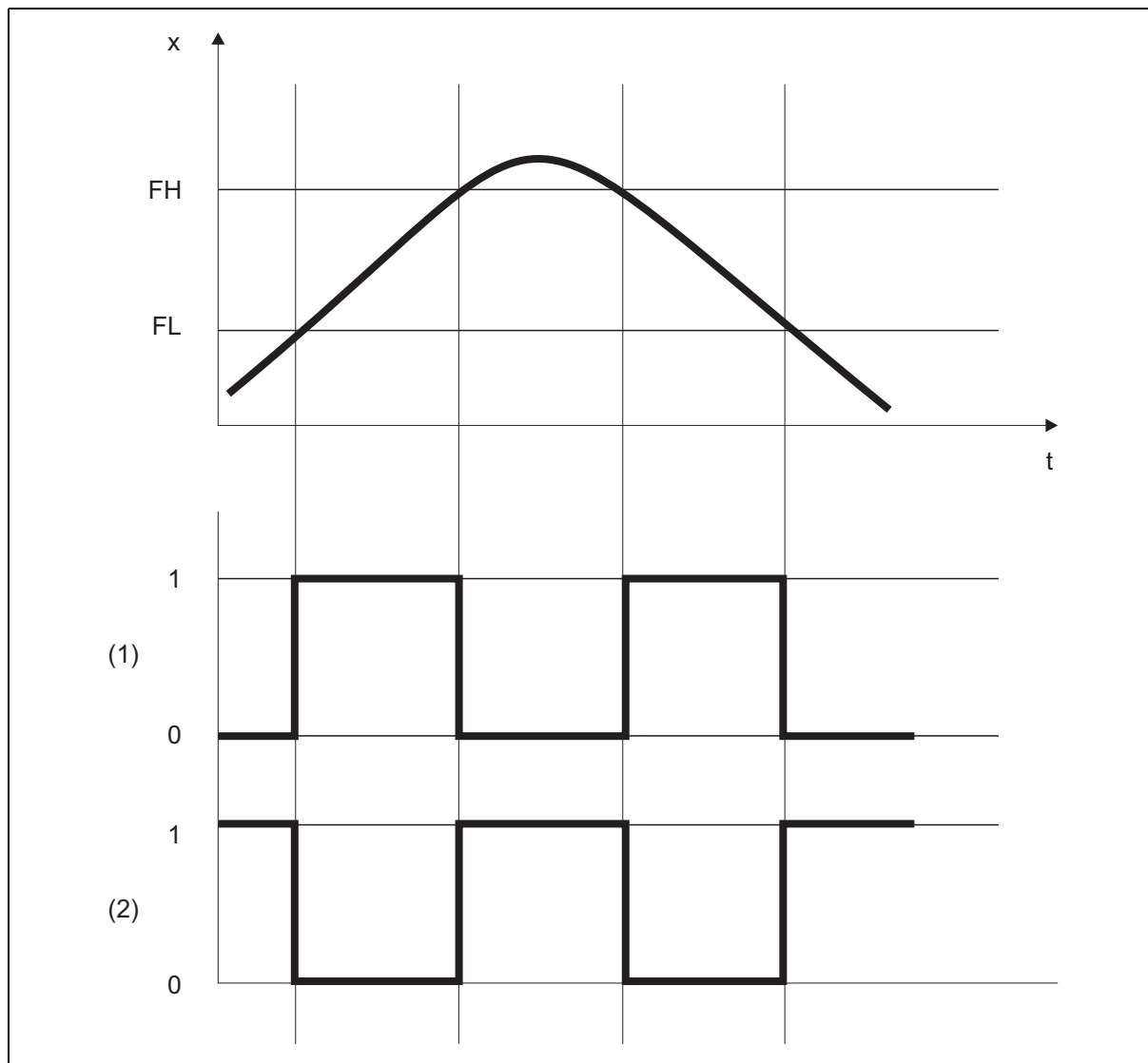

- x = Measured value
- t = Time
- FH = Window high
- FL = Window low
- (1) = N/O contact
- (2) = N/C contact

## 6.1.3 Switch-on delay/switch-off delay

The switch-on delay "VSP" and switch-off delay "VrSP" prevent switching of the output being triggered by peaks or drops in the measured values.

If the necessary measured value is no longer measured once the delay time has passed, the output is not switched.

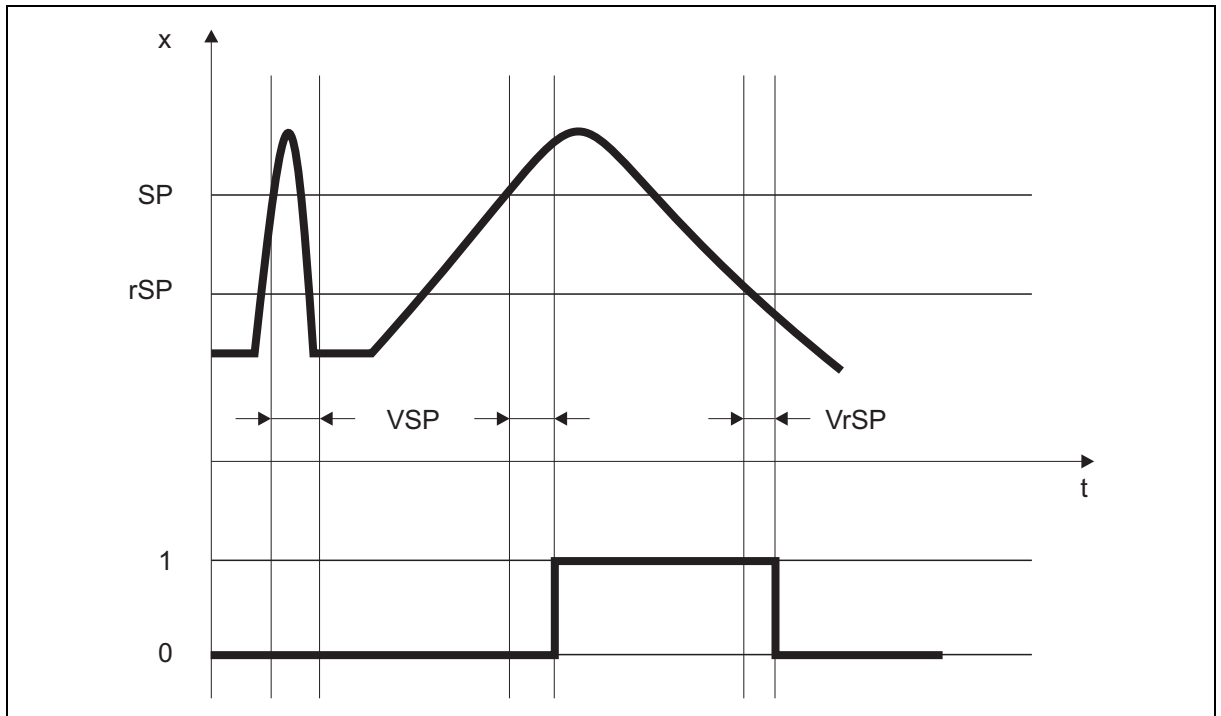

- $x$  = Measured value
- $t$  = Time
- SP = Switching point
- rSP = Release point
- VSP = Switch-on delay
- VrSP = Switch-off delay

# 6 Functions

## 6.2 Fine adjustment

You can use customer-specific fine adjustment to correct the measured values of the sensor. In contrast to offsetting, which is used to specify a constant correction value for the entire characteristic line, fine adjustment can also be used to change the gradient of the characteristic line.



### NOTE!

This data is not stored in the parameter manager.

### Parameter

Parameter	Selection/settings	Description
Active	No, Yes	Fine adjustment is only active if you select Yes
Actual start value	-999 to 0 to +999	Lower measured value
Target start value	-999 to 0 to +999	Lower reference value
Actual end value	-999 to 0 to +999	Upper measured value
Target end value	-999 to 0 to +999	Upper reference value

### Example

The temperature inside a furnace is measured and displayed. Due to a deviation in the measurement, the sensor's measured value does not correspond to the actual value (reference measurement). The amount of deviation is different at the upper and lower measuring points, meaning an offset correction is not suitable.

Active: Yes  
Actual start value: 15 °C (measured value)  
Target start value: 20 °C (reference measurement)  
Actual end value: 70 °C (measured value)  
Target end value: 80 °C (reference measurement)

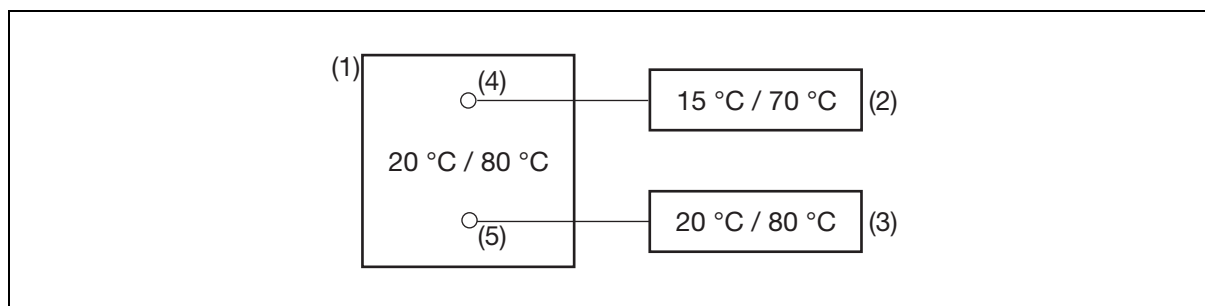

- (1) Furnace
- (2) Measured values from the sensor
- (3) Reference values
- (4) Sensor
- (5) Reference measurement



## Performing fine adjustment

- Determine the lower value (as low and constant as possible) with the reference measuring device.  
Example: Set furnace temperature to 20 °C.
- Enter the measured value as the actual start value and the reference value as the target start value.  
Example: Enter 15 and 20.
- Determine the upper value (as high and constant as possible) with the reference measuring device.  
Example: Increase furnace temperature to 80 °C.
- Enter the measured value as the actual end value and the reference value as the target end value.  
Example: Enter 70 and 80.



### NOTE!

The actual start value and actual end value can also be selected with the teach function.  
⇒ chapter 6.3 "Teach functions", Page 26

## Characteristic line

The following diagram shows the changes in the characteristic line caused by the fine adjustment (point of intersection with the x axis as well as the gradient).

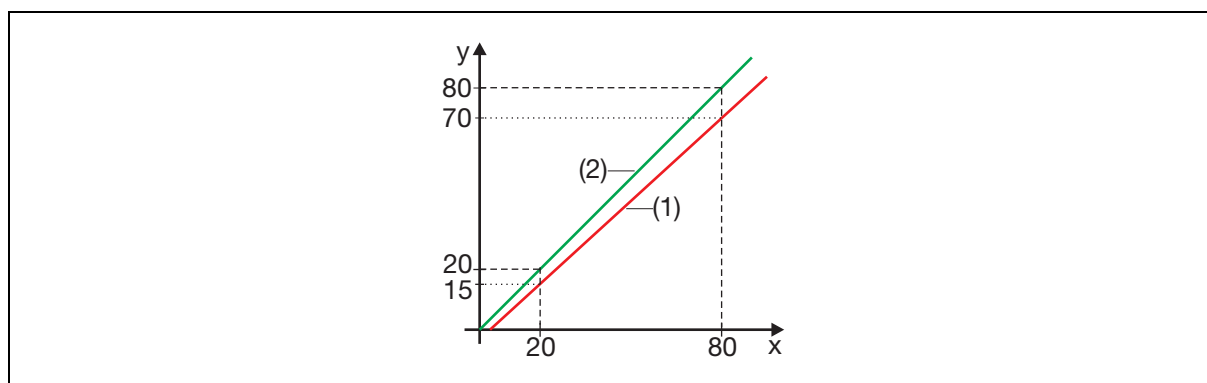

- y    Measured value  
x    Reference value  
(1)   Characteristic line before fine adjustment  
(2)   Characteristic line after fine adjustment

## Resetting the fine adjustment

To reverse the fine adjustment, the "Active" parameter must be set to "No".

# 6 Functions

---

## 6.3 Teach functions

The teach functions can be used to transfer certain commands to the sensor.

### Teach functions in the area of "General parameters"

Teach function	Description
Reset to default settings	All parameters under "General parameters", "Switching points", "Fine adjustment" and "Event settings" are reset to the default settings. The parameters under "Service information" stay the same.

### Teach functions in the area of "Fine adjustment"

Teach function	Description
Set actual start value	The current measured value is adopted as the actual start value.
Set actual end value	The current measured value is adopted as the actual end value.

### Teach functions in the area of "Service information"

Teach function	Description
Reset all	All parameters under "Service information" are reset to the default settings.
Reset operating hours counter	The operating hours counter is reset to the default settings.
Reset drag indicator min.	The stored minimum value is reset to the default settings.
Reset drag indicator max.	The stored maximum value is reset to the default settings.



#### NOTE!

After executing a teach function, the data may have to be exported from the sensor again in certain circumstances.

---

## 6.4 Fault signaling

IO-Link offers a range of fault signaling options (device status, event codes, PDValid-Flag). Furthermore, malfunctions can also be signaled within the process data via the process value itself or the status of the process value.

### Overview

Description	Signaling via process value in PDI <sup>a</sup>	Process value status in PDI (1 byte)	Device status	Event code (Standard event)	Event activation or deactivation possible	Event error type
No error	-	-	0 (device is working properly)	-	-	-
Process value invalid	Yes	Bit0 (Process data invalid)	4 (failure)	0x1000	Yes	Error
Overrange	Yes			0x8C20	Yes	Error
Underrange	Yes				Yes	Error
Error in configuration data	No	Bit1 (Parameter error)	4 (failure)	0x6320	No	Error
Error in calibration data	No	Bit2 (Device is defective)	4 (failure)	0x5000	Yes	Error
Device is defective (Probe break, probe short circuit)	Yes					
Undervoltage	No	-	2 (Outside the specification)	0x5111	No	Warning
Temperature error, overload	No	-	4 (failure)	0x4000	No	Error

<sup>a</sup> PDI = Process Data Input

# 6 Functions

---

## Device status and event codes

Various events can be activated or deactivated via configuration parameters.

### PD-Valid Flag

If the device status is 4 (failure), the PDValid-Flag is set to zero (false). This means that all of the process data is invalid. In order to determine the precise cause, the process value or status bits can be evaluated.

### Process value

The fault signaling is displayed as a floating-point value or integer value. The following statuses are defined:

Error	Error code for floating-point values (TFLOAT)	Error code for integer values (TINT32)
Measuring range underflow	$1.0 \times 10^{37}$	2147483638
Measuring range overflow	$2.0 \times 10^{37}$	2147483639
Not a valid input value	$3.0 \times 10^{37}$	2147483640
Division by zero	$4.0 \times 10^{37}$	2147483641
Mathematical error	$5.0 \times 10^{37}$	2147483642
Probe short circuit	$7.0 \times 10^{37}$	2147483644
Probe break	$8.0 \times 10^{37}$	2147483645

### Process value status

⇒ See chapter 7.1 "Process data", Page 29

## 7.1 Process data

The data is transferred in a cycle via the IO-Link interface to the IO-Link master (PDI = Process Data Input). The entire process data can be extracted via index 40 and subindex 0.

Designation	Data type	Value range	Default	Description
Temperature process value	TFLOAT or TINT32		0	The "Data format" configuration parameter can be used to switch between the data type TFLOAT and TINT32. ⇒Chapter 7.2
Temperature process value unit	TUINT8	0 = °C 1 = °F	°C	
Temperature process value status	TUINT8 (bit field)	Bit 0 = Process value invalid (overrange or underderrange) Bit 1 = Error in configuration data Bit 2 = Error in calibration data (device is defective)	0	In order to provide a simple way to identify errors, alongside IO-Link's standard troubleshooting functions, a status byte is included in the process data. This signals errors in the sensor and is easy to analyze in the higher-level system. Errors are entered on a bit by bit basis but can also be combined to contain several device errors. ⇒Chapter 6.4
Switching output	TUINT8 (bit field)	Bit 0 = Switching output 1 Bit 1 = Switching output 2	0	0 = Not switched 1 = Switched

# 7 Parameter overview

---

## 7.2 Configuration data

The configuration is stored in the parameter manager and is transferred via the IO-Link interface in an acyclic process.

### General

Designation	Index	Subindex	Data type	Value range	Default	Access right <sup>a</sup>	Description
Data format	64	0	TENUM (1 byte)	0 = Floating point 1 = Integer	Floating point	RW	
Temperature process value unit	120	0	TENUM (1 byte)	0 = °C 1 = °F	°C	RW	
Temperature process value offset	121	0	TFLOAT	-999 to 999	0	RW	
Temperature filter time constant	122	0	TFLOAT	0 to 100 s	0	RW	
Standard command	2	0	Button	130 = Reset to default setting	-	WO	The default data is loaded.

<sup>a</sup> RW = Read and write access  
RO = Read-only access  
WO = Write-only access

## 7 Parameter overview

### Switching output 1 and 2

Designation	Index	Sub-index	Data type	Value range	Default	Access right	Description
Switching behavior	200 and 201	1	TENUM	0 = Inactive 1 = Hysteresis function N/O contact 2 = Hysteresis function N/C contact 3 = Window function N/O contact 4 = Window function N/C contact	Inactive	RW	Index 200 = Switching output 1 Index 201 = Switching output 2
Switching point/ Window high	200 and 201	2	TFLOAT	-999 to 999	0	RW	
Release point/ Window low	200 and 201	3	TFLOAT	-999 to 999	0	RW	
Switch on Delay	200 and 201	4	TFLOAT	0 to 100 s	0	RW	
Switch off Delay	200 and 201	5	TFLOAT	0 to 100 s	0	RW	
Output mode	200 and 201	6	TENUM (1 byte)	0 = p-switching 1 = n-switching	p-switching	RW	

### Events

Designation	Index	Sub-index	Data type	Value range	Default	Access right	Description
Event settings	111	0	TUINT8 (bit field)	Bit 0 = Process data invalid Bit 1 = Process data overrange Bit 2 = Process data underrange Bit 3 = Device hardware error	0	RW	0 = Inactive 1 = Active

## 7 Parameter overview

---

### Fine adjustment data

Designation	Index	Subindex	Data type	Value range	Default	Access right	Description
Active	220	0	TENUM (1 byte)	0 = No 1 = Yes	No	RW	
Actual start value	221	0	TFLOAT	-999 to 999	0	RW	
Actual end value	222	0	TFLOAT	-999 to 999	0	RW	
Target start value	223	0	TFLOAT	-999 to 999	0	RW	
Target end value	224	0	TFLOAT	-999 to 999	0	RW	
Standard command	2	0	Button	160 = Set actual start value	-	WO	
Standard command	2	0	Button	161 = Set actual end value	-	WO	



#### NOTE!

This data is not stored in the parameter manager and is transferred via the IO-Link interface in an acyclic process.

---



### 7.3 Service data

The service data is written to the EEPROM in a cyclical process (every 10 minutes) and can be reset via the teach functions.

Designation	Index	Sub-index	Data type	Value range	Access right	Description
Operating hours counter	3000	0	TUINT32		RO	
Drag indicator temperature process value min.	3002	0	TFLOAT		RO	
Drag indicator temperature process value max.	3003	0	TFLOAT		RO	
Reset all	3100	0	Device command	1 = Reset	WO	Resets all drag indicators and the operating hours counter
Reset operating hours counter	3100	0	Device command	2 = Reset	WO	
Reset drag indicator temperature min.	3100	0	Device command	3 = Reset	WO	
Reset drag indicator temperature max.	3100	0	Device command	4 = Reset	WO	
VDN version	1000	0	TSTRING	12 byte	RO	
Bootloader version	1001	0	TSTRING	14 byte	RO	

## 8 Technical data

### 8.1 Input

Sensor element	RTD temperature probe Pt1000
Standard	DIN EN 60751
Measuring range	902915/10: -50 to +150 °C 902915/30: -50 to +260 °C
Sensor accuracy	Class A, $\pm(0.15 + 0.002 \times  t )$ °C <sup>a</sup> Class AA, $\pm(0.10 + 0.0017 \times  t )$ °C <sup>a</sup>
Connection type	Resistance measurement 4-wire
Calibration accuracy of the electronic components	$\leq \pm(0.08 \%)^b$
Ambient temperature influence	$\leq 0.0025 \%/K^{b, c}$
Measuring current	$\leq 500 \mu A$
Sampling rate	160 ms
Input filter	Digital filter, 2nd order; filter constant can be set
Galvanic isolation	to the protection tube; no galvanic isolation between sensor and output

<sup>a</sup>  $|t|$  = temperature value in °C regardless of the prefix sign.

<sup>b</sup> All accuracy specifications in % relative to the respective measuring range

<sup>c</sup> Relative to the temperature deviation at the calibration point (25 °C  $\pm$ 5 K)

#### Measuring circuit monitoring

Process data invalid	IO-Link event configurable; appears in the process value as an error value
Measuring range overflow	
Measuring range underflow	
Device hardware fault	

### 8.2 Output

Number	1 output in IO-Link operation (output signal according to IO-Link communication standard version 1.1; see section "Interface", Page 35) 2 outputs for switch operation (SIO mode; SIO = standard IO)	
Switching functions configurable	Hysteresis function or window function N/C or N/O contact Output p switching (PNP) or n switching (NPN) Switch-on/switch-off delay	
Switching current	≤100 mA per output	
Voltage drop at switching transistor	≤2 V	
Short-circuit proof	Yes (clocked)	
Reverse polarity protected	Yes	
Current limiting	Yes	
Hysteresis	Configurable	
For hysteresis function	Configurable	
For window function	Fixed setting (symmetrical; ±0.25 % of the measuring range)	
Switch-on, switch-off delay	0 to 100 s	
Response time	In water 0.4 m/s	In air 3.0 m/s
Protection tube Ø 6 mm (standard)	$t_{0.5} = 5 \text{ s}; t_{0.9} = 12 \text{ s}$	$t_{0.5} = 40 \text{ s}; t_{0.9} = 110 \text{ s}$
Protection tube Ø 6 mm (offset by Ø 3.5 mm)	$t_{0.5} = 2 \text{ s}; t_{0.9} = 5 \text{ s}$	$t_{0.5} = 25 \text{ s}; t_{0.9} = 85 \text{ s}$
Protection tube Ø 3 mm (PA 379)	$t_{0.5} = 1.5 \text{ s}; t_{0.9} = 4 \text{ s}$	$t_{0.5} = 15 \text{ s}; t_{0.9} = 50 \text{ s}$

### 8.3 Interface

Communication interface	IO-Link device V 1.1, downward compatible to V 1.0
Data transfer rate (baud rate)	COM 3 (230.4 kBaud)
Max. cable length	20 m, unshielded
Min. cycle time	2 ms
IO Device Description (IODD)	Depending on the ordered input range; available on the manufacturer's website <a href="http://www.jumo.de">www.jumo.de</a> or at <a href="http://ioddfinder.io-link.com">http://ioddfinder.io-link.com</a>

## 8 Technical data

---

### 8.4 Electrical data

Voltage supply	
In IO-Link operation	DC 18 to 32 V
In switch operation	DC 9.6 to 32 V
Nominal voltage	DC 24 V
Current consumption	
In idle mode	≤16 mA
In IO-Link operation	≤20 mA
In switch operation	≤200 mA (with 2 switching outputs)
Electrical safety	Protection rating III according to DIN EN 61140
Intended use	Temperature measurement in industrial plants

The auxiliary energy of the temperature sensor must meet SELV requirements. Furthermore, the device must be equipped with an electrical circuit that meets the requirements of EN 61010-1 with regard to "Limited-energy circuits".

### 8.5 Mechanical features

Materials	
Protection tube	Stainless steel 1.4404 (1.4435 for clamp acc. to DIN 32676)
Process connection	Stainless steel 1.4404 (1.4435 for clamp acc. to DIN 32676)
Housing	Stainless steel
Installation position	Any
Weight <sup>a</sup>	902915/10 with PA 104 and EL = 100 mm: approx. 80 g 902915/30 with PA 104 and EL = 100 mm: approx. 120 g

<sup>a</sup> The weight of the temperature sensor depends on the process connection (PA) and the insertion length (EL).

### 8.6 Environmental influences

Admissible temperatures	
Medium	902915/10: -50 to +150 °C 902915/30: -50 to +260 °C
Ambient temperature <sup>a</sup>	-40 to +85 °C (ambient temperature range of the head)
Storage	-40 to +85 °C
Resistance to climatic conditions	
During operation	≤100 % humidity without condensation on the outer skin of the device
During storage	≤90 % relative humidity without condensation
Climate class	3K7 acc. to DIN EN 60721-3-3
Admissible mechanical load	
Vibration resistance	10 g, at 10 to 500 Hz acc. to DIN EN 60068-2-6
Shock resistance	20 g for 11 ms according to DIN EN 60068-2-27 50 g for 1 ms according to DIN EN 60068-2-27
Process media	Liquid and gaseous media
Protection type	According to DIN EN 60529
With mating connector	IP66/IP67/IP69
Electromagnetic compatibility	According to EN 61326-2-3
Interference emission	Class B <sup>b</sup>
Interference immunity	Industrial requirement

<sup>a</sup> Basic type 902915/10: At process temperatures above 120 °C, the maximum admissible ambient temperature is 60 °C (stated at nominal voltage DC 24 V).

Basic type 902915/30: No restrictions (stated at nominal voltage DC 24 V).

<sup>b</sup> The product is suitable for industrial use as well as for households and small businesses.

 有毒有害物质或元素 Hazardous substances		铅 (Pb)	汞 (Hg)	镉 (Cd)	六价铬 (Cr(VI))	多溴联苯 (PBB)	多溴二苯醚 (PBDE)
		部件名称 Product group: 902915 外壳 Housing (Gehäuse) 过程连接 Process connection (Prozessanschluss) -螺母 Nut (Mutter) 螺钉 Screw (Schraube)	○	○	○	○	○
本表格依据 SJ/T 11364-2014 的规定编制。 (This table is prepared in accordance with the provisions of SJ/T 11364-2014.) O : 表示该有害物质在该部件所有均质材料中的含量均在 GB/T 26572 规定的限量要求以下。 (O: Indicates that said hazardous substance contained in all of the homogeneous materials for this part is below the limit requirement of GB/T 26572.) X : 表示该有害物质至少在该部件的某一均质材料中的含量超出 GB/T 26572 规定的限量要求。 (X: Indicates that said hazardous substance contained in one of the homogeneous materials used for this part is above the limit requirement of GB/T 26572.)							





**JUMO GmbH & Co. KG**

Street address:  
Moritz-Juchheim-Straße 1  
36039 Fulda, Germany

Delivery address:  
Mackenrodtstraße 14  
36039 Fulda, Germany

Postal address:  
36035 Fulda, Germany

Phone: +49 661 6003-0  
Fax: +49 661 6003-607  
Email: [mail@jumo.net](mailto:mail@jumo.net)  
Internet: [www.jumo.net](http://www.jumo.net)

**JUMO Instrument Co. Ltd.**

JUMO House  
Temple Bank, Riverway  
Harlow, Essex, CM20 2DY, UK

Phone: +44 1279 63 55 33  
Fax: +44 1279 62 50 29  
Email: [sales@jumo.co.uk](mailto:sales@jumo.co.uk)  
Internet: [www.jumo.co.uk](http://www.jumo.co.uk)

**JUMO Process Control, Inc.**

6724 Joy Road  
East Syracuse, NY 13057, USA

Phone: +1 315 437 5866  
Fax: +1 315 437 5860  
Email: [info.us@jumo.net](mailto:info.us@jumo.net)  
Internet: [www.jumousa.com](http://www.jumousa.com)

